



Introduction to Community Innovation

Participant Handbook



Overview

Participants in this program will learn the fundamentals of digital fabrication and electronics, including 3D modeling and printing, laser cutting, CNC machining, and Arduino. However, at the Bronx Innovation Factory, we do not teach these skills in isolation. Instead, we believe that these are tools for Bronxites to create new products and businesses that contribute to a more just, equitable, and sustainable Bronx economy. Accordingly, participants will also learn about the innovation process, technology as an economic sector, and *economic democracy*—the idea that Bronxites should share ownership over the resources in our community and participate equally in deciding how they are used.

Beyond the material contained in this pages, participants will work in teams to apply these skills, identifying community challenges and developing and testing possible solutions. Participants will walk away understanding how to recognize community challenges and how to design, build, and test solutions using digital fabrication and electronics. Through theory and the practice of working collaboratively, they will also understand the basics of cooperative economics.

Technology alone will not solve inequality or oppression. It can, however, immediately improve some of the challenges low-income communities face as a result of these systems and provide a pathway to shared wealth creation and ownership, which *can* serve to challenge and subvert those systems. At the Bronx Innovation Factory, we believe that Bronxites already have the knowledge to solve our most pressing challenges and that the lived experiences of Bronxites are a key source of knowledge to drive technological innovation forward in more just and equitable ways. Through this program and others, we hope to nourish and support Bronxites' creativity.

* * *

The Bronx Innovation Factory is a center for advanced manufacturing led by women and people of color, focused on shared wealth creation and innovations that matter for Bronx residents. It is



a project of the Bronx Cooperative Development Initiative, a grassroots-led effort to build an equitable, sustainable, and democratic local economy that builds wealth and ownership for low-income people of color. Learn more at bronxinnovation.org.



Table of Contents

Overview	1
Foundations of Digital Fabrication & Electronics	4
Laser Cutting and Adobe Illustrator	6
CAD and 3D Printing	10
CNC Machining and CAM	17
Electronics	23
Soldering & Electricity	48
Foundations of Community Innovation	52
Economic Democracy	53
Technology and Society	58
The Innovation Process	66
Product Design	72
Product Lifecycle and Sustainability	76
Intellectual Property	84
Developing a Pitch	88



Foundations of Digital Fabrication & Electronics

Digital fabrication is disrupting tradition, power, and expectations. But what is it? In short, digital fabrication is a type of design and production process that uses computer software and machines to manufacture goods. This includes both additive manufacturing, where material is added to form an object, and subtractive manufacturing, where it is cut away from an existing block or length of material to create a new object. Specific digital fabrication machines includes laser cutters, 3D printers, and CNC routers. Electronics are a form of technology that can power almost any machines or tool you can think of by way of circuits, transistors, and microchips. As tiny pieces, electronics can be assembled and programmed in different ways to be interactive, flexible, and creative. Together these form the basis of what is known as *advanced manufacturing*.

Digital fabrication and electronics require knowledge of various design and programming softwares. As part of the Bronx Innovation Factory workshops, we will go over the basics of these skills and build comfort with the machines.

But, before we get started—why? Why is digital fabrication a model for future manufacturing? Why will these skills matter, and how will they make a difference?

As compared to traditional manufacturing, digital fabrication offers opportunities for highly customizable products, cheaper design and production processes, and faster completion times. In

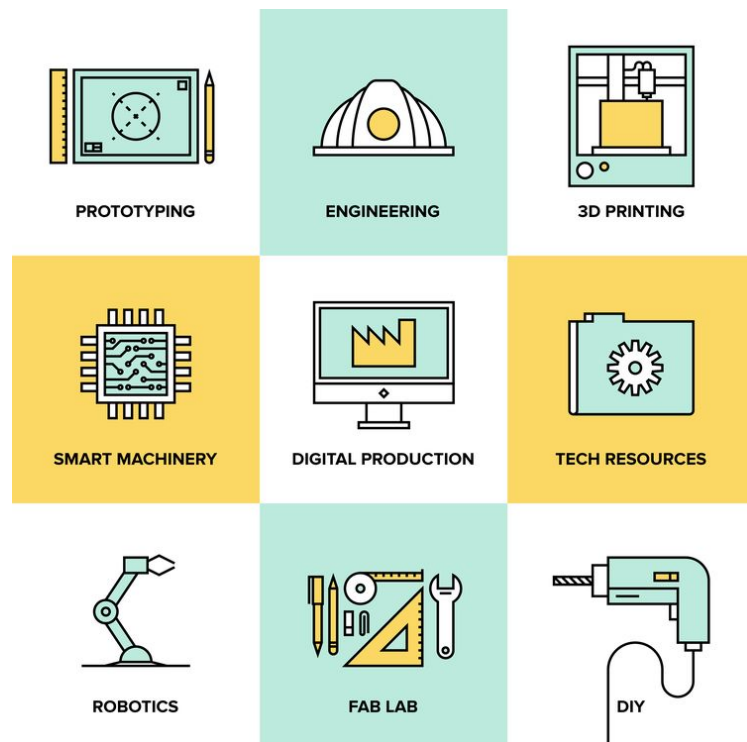



some cases, it can also reduce the environmental impact of manufacturing by consolidating the number of individual parts produced and reducing the distance between producer and end user.

Importantly, digital fabrication and electronics don't take a lot of training or expensive equipment to get started. Arduino kits cost around \$30; you could build your own 3D printer for just a few hundred dollars. Digital fabrication thus has the potential to disrupt the traditional power structures that have controlled which products are made and who can make them. In this way, digital fabrication is democratizing innovation, and we believe supporting Bronx residents with these technical skills can drive innovation in our community unlike any that we've ever seen. As we go through each of these digital fabrication lessons, keep community change and innovation in the back of your mind.



Laser Cutting and Adobe Illustrator

Goals:

- Understand how the laser cutter works and what you can make with it
- Understand how to create your own designs using Adobe Illustrator

Key Terms

Laser Cutter: A prototyping machine that uses a laser beam to cut or etch designs and products.

Etching: Also known as *engraving* or *rastering*. Etching carves shapes and text into the top layers of the material's surface without fully cutting through the material.

Cutting: Also known as *vectoring*. Cutting creates text and shapes by fully removing material being cut into.

Hairline width: The width of the line at 0.072 pt or less.

Cut bed: Surface where the material that will be cut or etched is placed.

Gantry: A bridge-like frame structure that supports and moves the laser cutter's lens according to X, Y, and Z coordinates.

Ventilation: The ventilation system carries away the toxic gas, smoke, small particulate matter, and odors that the laser creates. The ventilation keeps the laser cutting process safe for people in the room.



Key Questions:

What can a laser cutter do?

A laser cutter can *cut* or *etch* 2D designs in a number of materials including wood, cardboard, acrylic, leather, and many more. Laser cutters are great for simple projects like keychains or bookmarks, as well as more complex projects like lampshades or the interlocking pieces of a 3D laptop stand.

How does the laser cutter work?

The laser cutter uses a set of four mirrors to focus a laser beam to the point that it burns the material on the *cut bed*. (This is like when you focus a magnifying glass so it lights a piece of paper on fire). The *gantry* on the laser cutter will move the fourth and final mirror and the corresponding lens around so that the laser beam burns the material in the desired shape.

Because burning create smoke and fumes, which can be dangerous to humans, proper *ventilation* is extremely important.

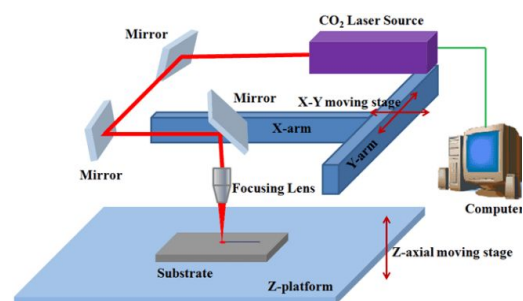
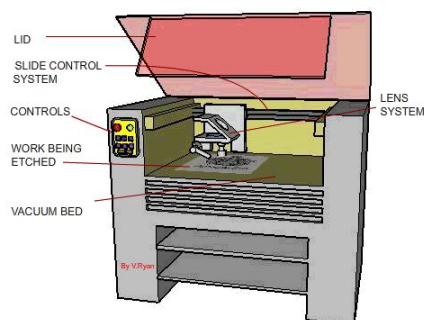

Image source: TechnologyStudent.com



How do I create a design for the laser cutter?

In order for the laser cutter to make what you want, you need to create a 2D design that speaks to the laser cutter in the language it understands. Adobe Illustrator is one program that can do this, and we will use it throughout this class. Other, free programs include Inkscape and Vecteezy.

- If you want the laser cutter to *cut*, you will have to create a *hairline-weight* line. This is how the laser cutter knows you want to cut.
- If you want the laser cutter to *etch*, you can create a thicker line or a filled-in shape. The laser cutter will interpret these as *raster* images and will etch.

Additional Resources:

- [Thingiverse](https://www.thingiverse.com)¹ provides downloadable designs and projects for laser cutting and 3D printing.
- [Laser-cut Pixar lamp](https://makezine.com/projects/laser-cut-pixar-luxo-lamp/)²
- [Laser-cut nori for sushi](https://makezine.com/projects/laser-cut-sushi/)³
- [Laser cutting techniques and project ideas](https://makezine.com/2013/10/23/tutorial-laser-cutting-techniques-and-projects/)⁴

Exercise: Bookmark Design

Goal: The goal of this exercise is to create your own bookmark using the laser cutter, Adobe Illustrator, and the techniques we went over in this session. The steps here are purposely vague—we want you to be creative in designing your bookmark. Ask questions about things you don't understand, but don't worry if your steps are different from others in class.

Step 1: Start with a shape you want your bookmark to be in—probably a rectangle, but you can think outside the box too! Draw this shape in Adobe Illustrator. Remember to pay attention to things like the line stroke, color, etc.

¹ <https://www.thingiverse.com>

² <https://makezine.com/projects/laser-cut-pixar-luxo-lamp/>

³ <https://makezine.com/projects/laser-cut-sushi/>

⁴ <https://makezine.com/2013/10/23/tutorial-laser-cutting-techniques-and-projects/>



Step 2: Fill in the bookmark shape with whatever text you want.

Step 3: Play with different elements of the text (size, line stroke, color). Think about the three different letter examples and decide how you want the bookmark text to appear (cut vs. etch).

Step 4: Adjust the settings for the printer. Things to adjust include placement, piece size, auto focus, laser speed.



CAD and 3D Printing

Goals:

- Understand how the 3D printer works and what you can make with it
- Understand 3D modeling software, and how to convert from 2D or 3D
- Understand the process of reverse-engineering

Key Terms

Additive manufacturing: The process of creating objects by building one layer at a time. This process uses less materials and time than more traditional manufacturing methods.

3D printing: A specific additive manufacturing process that creates a 3D object by layering materials according to a digital design.

CAD (aka computer-aided design): Software technology (such as AutoCAD) that's used to create designs.

Reverse-engineering: The reproduction of a 3D object following detailed examination of its construction or composition.

Supports: These can be breakaway supports, made of the same material as the 3D print, or can be printed in a different water-soluble material that can be washed away to leave the final 3D printed object.

PLA: Biodegradable plastic used for 3D printing. PLA has a low printing temperature, making it easier than other plastics to print with. Short for Polylactic Acid.

TPU: Plastic used for 3D printing. TPU has a rubber-like elasticity, making it more flexible than other plastics. Short for ThermoPlastic Polyurethane.

.stl: File format for CAD software used for 3D printing. Short for stereolithography.



Key Questions:

What can you make with a 3D printer?

The possibilities are literally endless. Here are just some examples:

- [Sneakers](#)⁵
- [Robots](#)⁶
- [Drones](#)⁷
- [Homes](#)⁸

How does a 3D printer work?

There are several types of 3D printers, all of which function slightly differently. Two of the most common types are:

- Fused deposition modeling (FDM) 3D printers melts and extrudes plastic through a printhead. In this way, it is the most simple to a traditional inkjet printer, which deposits colored ink according to a 2D file. In the case of FDM 3D printers, the printhead deposits successive layers of plastic on top of one another to built a 3D objects. Before you can print a 3D design, specialized software must “slice” the object into cross-sections to know what to print for each layer. The Bronx Innovation Factory has an Ultimaker FDM 3D printer.
- Stereolithography (SLA) 3D printers convert liquid materials into solid parts, layer by layer, by selectively curing them using a light source in a process called photopolymerization.

We can print in several different materials:

- PLA
- TPU
- ABS

⁵ https://www.youtube.com/watch?v=2_Mz8saTcRI

⁶ <https://www.youtube.com/watch?v=Zsw35FpJSz0>

⁷ <https://www.youtube.com/watch?v=92wIASzGKbl>

⁸ <https://www.youtube.com/watch?v=GUdnrtnjT5Q>



- PVA
- Nylon

How do you create a 3D file?

We use Fusion 360, which can be downloaded for free if you're an educator or hobbyist.

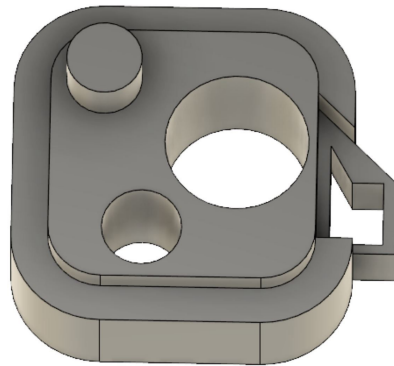

Here are some especially useful functions in Fusion 360:

- Draw - Allows you to create and edit a shape that you design
- Extrude - Allows you to create a 3D shape from a 2D shape by pulling an edge or panel outwards
- Cut - Allows you to trim parts of the shape from the body
- Union- Allows you to combine two or more shape bodies
- Fillets- Allows you to round corners of a shape or object

How do you reverse engineer?

Reverse engineering allows you to recreate any 3D object that you come across. First, ask yourself, what is the overall shape that I can draw first? Then, what can I add or subtract from that shape to get close to the shape of the object? In the exercises on the following pages, you will reverse engineer a tablet stand and a stool.

How do you print a 3D file?



In order to print for the Ultimaker 3D printer at the Bronx Innovation Factory, we will use a software called Cura. Once you design the 3D file, convert this file to an .stl file and open in Cura.

Once in Cura, you need to adjust the settings that affect your final 3D printout. Some settings to adjust include infill, layer, height, thickness, material specifications, print out speed, etc. Before printing, another important consideration is the design's orientation for print out. Make sure that the orientation allows the printing process to be as easy as possible. Once the settings are ready, hit the print button.

Additional Resources

- [7 shocking 3D-printed things](#)⁹
- [2D-printed chocolate](#)¹⁰
- [3D printed project ideas](#)¹¹ with free files from New York City-company, Adafruit
- [Fusion 360 How To](#)¹² video

⁹ https://www.youtube.com/watch?v=TAp93r_q1Fc

¹⁰ <https://www.youtube.com/watch?v=slksoDJPJ94>

¹¹ <https://www.youtube.com/watch?v=l0AmRR9w0nw>

¹² <https://www.youtube.com/watch?v=7B9wem3vCVQ>



Exercise 1: Tablet Stand

Goal: The goal of this exercise is to create a stand that can hold a tablet device. For this exercise, we're not giving you the dimensions of the stand—we want you to create a stand that is whatever size you want—but the stand must be proportional.

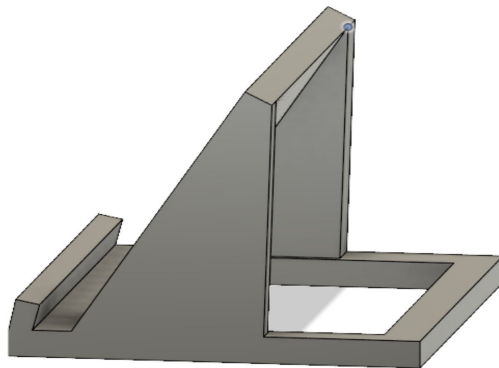

Step 1: Create the base

- Create a rectangle
- Extrude the rectangle
- Cut a rectangular hole
- Extrude the hole

Step 2: Build front and back supports

- Zoom to the side plane
- Draw the front support
- Draw the back support
- Extrude both shapes

Step 3: Build side supports

- Draw the side supports
- Extrude those shapes

Step 4: Convert to .stl



- Save the shape with the extension .stl

Step 5: Adjust settings in Cura. The recommended settings are:

- Print speed - automatic, does not need to be tampered with.
- Infill - normally we use 20%.
- Generate support - depends on the design, if angles are over 45 degrees.
- Build plate adhesion - depends on design, if plate is needed.

Exercise 2: Support Part

Goal: The goal of this exercise is to create a support part—first by creating your own sketch and then by printing. In this exercise, we're giving you the dimensions to replicate, but you can begin the drawing however you want. There is no correct way to start the drawing—just try whatever makes the most sense to you.

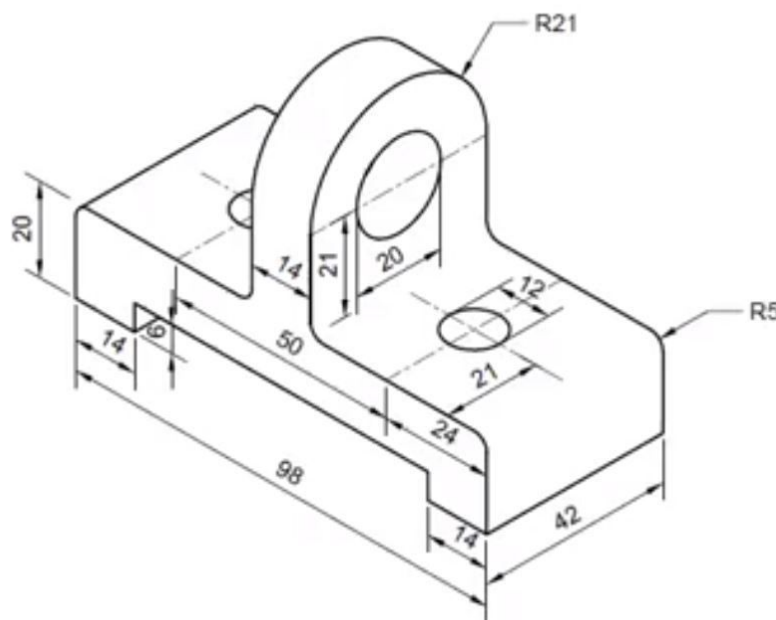

Step 1: Look at the sketch above and brainstorm on the different ways to begin the drawing. Think about where you want to start the drawing. Why start there?



Step 2: After thinking about where to start, begin drawing your own support part design in CAD. Remember to follow the dimensions in the sketch above.

Step 3: After your sketch is ready to print, open the .stl file in Cura. Review the different settings in Cura. Are these the settings you want to keep? If you adjusted the settings, how would this change the printing process?



CNC Machining and CAM

Goals:

- Understand how CNC machines work
- Understand how to prepare 3D files for the CNC machine
- Understand how to use the CNC machine

Key Terms

CNC machine: These machines use code to cut and carve different materials (plastic, wood, foam, etc.). CNC stands for computer numeric controlled.

XYZ coordinate system: The basis for how the machine understands the dimensions of a material. The machine uses the coordinate system to move across the material and cut/carve. X and Y are horizontal length and width, and, Z is vertical depth.

2D Pocket: machine operation that removes material to create a particular shape and has the option to finish the material.

Contour: machine movement that produces curves, circles, or cones.

CAM (aka computer-aided manufacturing): Software used by CNC machines to control movements for manufacturing. CAM software that's used at the Bronx Innovation Factory is Fusion 360.

G-code: programming language for CNC machine operations.

Key Questions:

What are the different parts of a CNC machine?

Some of the important parts of the CNC machine to know include:



- **Bit/end mill:** The removable, moving piece of CNC machine that is responsible for cutting or carving materials. This comes in different forms for different effects and materials.
- **Chuck:** the piece of the CNC machine that holds the bit in place.
- **Vacuum system:** Important function that removes the waste material that's created in the cutting/carving processes.
- **Deck:** the bed where the material to be cut or carved is placed

What's the difference between CAD and CAM?

The two types of programs serve different functions, but can be used to complete one project. For example, CAD is used to design the object, whereas CAM is used to tell the machine how to produce the object.

What can the CNC machine create?

CNC machines can be used to create common objects and features such as cabinets, benches, and signs, as well as more artistic objects such as guitars and sculptures. Many common items can be carved in high-detail decoration using CAD and CAM softwares and the CNC machine. The machine can basically cut in 2.5D.

How does a CNC machine work?

The machine uses G Code and XYZ coordinates to track its location. (Our machine has 3 axes so just XYZ. Other machines have 4 or 5 axes and will use additional variables). An end mill carves away material.

How do you create files for the CNC machine?

Design files in CAD and then set parameters in CAM (including settings for the end mill, what direction you want the machine to cut in, etc.)



Additional Resources

- [What is CNC Machining and How Does it Work?](#)¹³
- [Beginner tips for CNC machining](#)¹⁴ (including what not to do)
- [Guitar body](#)¹⁵ created with a CNC machine

¹³ <https://www.youtube.com/watch?v=FNYEXjRmDtI>

¹⁴ https://www.youtube.com/watch?time_continue=44&v=uBVd8eAJclU

¹⁵ <https://www.youtube.com/watch?v=-7iWHeVOECs>



Exercise 1: Using CAM to Produce a Stool

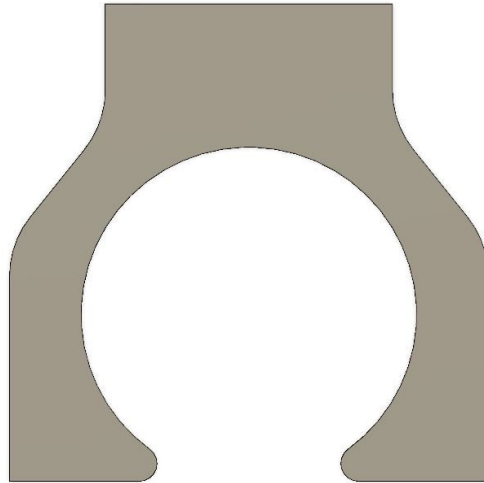

Goal: The goals of this exercise are to design a stool in CAM (Fusion 360) and then produce the stool on the CNC machine.

Phase 1: Draw stool design in Fusion 360.

1. Open Fusion 360 and start a drawing.
2. Draw center circle with a radius of 7 inches.
3. Draw a 20 inch horizontal line at the bottom of the circle tangential to the circle and aligned with the center of the circle.
4. Draw 12 inch horizontal line at the top of the circle, 13 inches from the center of the circle, aligned with the center line.
5. Draw the two bottom side vertical lines starting from the bottom end line, going up 12 inches.
6. Draw the top side vertical line starting from the ends of the top lines, down to 4 inches.
7. Connect the end of all the vertical lines, completing the drawing.
8. Add 4 inch fillets and extrude the drawing to the sheet thickness.
9. Create two small circles at the bottom, cut extrude.
10. Create center notches with sheet thickness + 0.08 inch.

Phase 2: Prepare file in CAM



1. Open CAM.
2. Create setup, select setup coordinate system and stock.
3. Select CNC operation from the different operations options and select end mill (or create endmill).
4. Select geometry of operation tab.
5. Select geometry.
6. Select multiple passes and select depth per pass.
7. Simulate to check CNC machining process.
8. Generate gcode.

Phase 3: Prepare and use the CNC machine.

1. Open Shopbot 3 for the design file.
2. Calibrate machine in accordance to CNC coordinate system.
3. Upload gcode file and begin to cut.



Exercise 2: Creating a Sign

Goal: The goal of this exercise is to create a square sign with text using CAM and CNC machining.



Step 1: Open Fusion 360 and create the shape of your sign.

Step 2: Create text for the sign.

Step 3: Once the design is ready, open the file in CAM to adjust the settings (setup, operations, end mill selection, etc.).

Step 4: Open Shopbot 3 and calibrate the machine.

Step 5: Upload gcode file and begin to cut.



Electronics

Goals:

- Understand what Arduino is, what it can do, and how to use it
- Understand how to assemble an Arduino and breadboard and what different components do
- Understand how to program an Arduino using the Arduino IDE

Key Terms

Microcontroller: A small computer with an integrated single circuit. This is used to complete one specific function or task. An Arduino is a programmable microcontroller.

Breadboard: A base unit for building temporary prototype circuits. This unit doesn't require metals to be fused together (known as soldering). The breadboard can be used to establish both simple and complex circuits.

Sensor: Device that detects and converts physical attributes to a form that can be measured. For example, the sensor will convert something like temperature, light, or humidity to an understandable form for humans or computers.

Actuators: The *mover* of the machine. In other words, the mechanical device that controls machine's movements.

Solderless: Not requiring the metals to be fused together.

Arduino programming language: A proprietary coding language specially developed for Arduino, also known as Arduino IDE.



Key Questions:

What is a microcontroller? What is Arduino?

A microcontroller is a small computer board, also known as an integrated circuit, that is used to complete or control very specific tasks involving automatic control. The microcontroller is programmable and is used to gather information, process that information, and perform actions based on the information.

Arduino is an open-source electronics platform including both hardware (Arduino boards) and software components (Arduino IDE). At the BXIF, we'll use both Arduino boards and the Arduino programming language.

What are the parts of your Arduino?

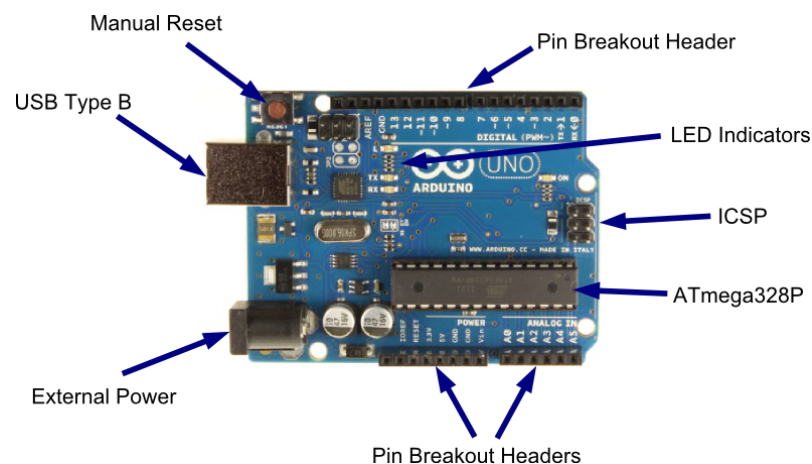

Image Source: <http://nborko.github.io/vc-arduino/#/36>

Looking at the image of the Arduino above, the components include:

- **Manual reset:** restarts the Arduino and restores the original code and hardware settings.
- **USB Type B:** Drive for a USB cable to connect the Arduino to another device (for example, your computer).
- **External power:** Drive to connect to an outside power source



- **Pin Breakout Header:** Space for connections between the Arduino shield and other components (for example, breakout boards) via pins and wires. Depending on the location, these pins have different functions (for example, power).
- **LED Indicators:** Indicator lights that light up for on board connections, transmission, receiving, and power.
- **ICSP:** These pins control the communication between the device and the microcontroller. ICSP stands for “in circuit serial programmer.”
- **ATmega328P:** The microcontroller and the “brains” of the Arduino shield. This is where the memory and RAM are stored.

How do you assemble Arduino? What is a breadboard?

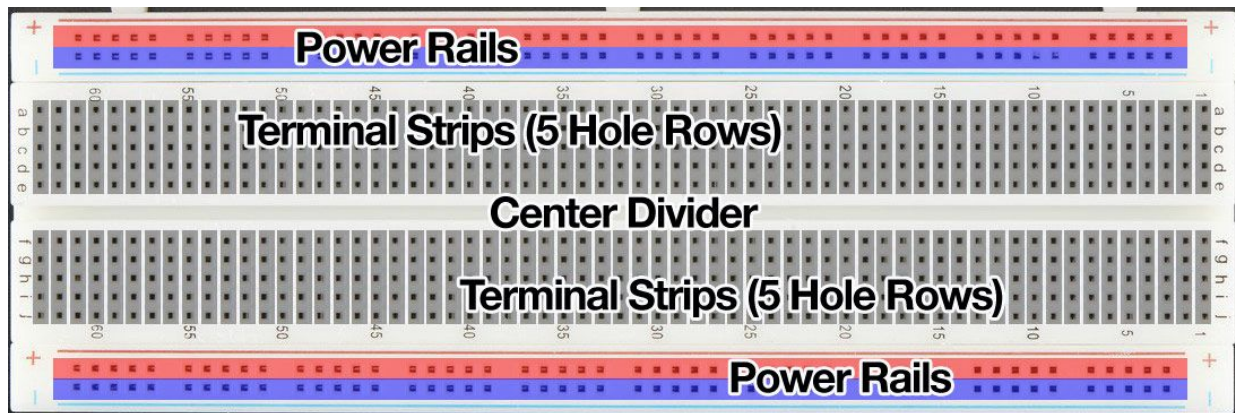

Source: Adafruit

A breadboard is a circuit board that is used to make temporary, electronic circuits that can be easily reassembled and reused. Breadboards are generally used in electrical engineering as an efficient, cost-effective, and reusable way to test different circuits and products. The electronic elements inside the circuits can be interchanged by inserting wires into the board’s holes, creating circuits.

Breadboards are solderless and are made of two kinds of strips – terminal and bus strips.

- **The terminal strips** are in the middle of the breadboard and handle internal connections. These strips hold the electronic elements.



- **The bus strips** or power rails are the two strips on the outer edges of the board and provide a power connection for all the electronic components.

In the above diagram you can see alphabets are used to identify vertical columns and numbers are used in order to identify horizontal columns.

In the below diagram you can see both the vertical and horizontal columns (and their holes) are internally connected by strips of metal. As soon as the power is turned on, the current flows through these internal connections.

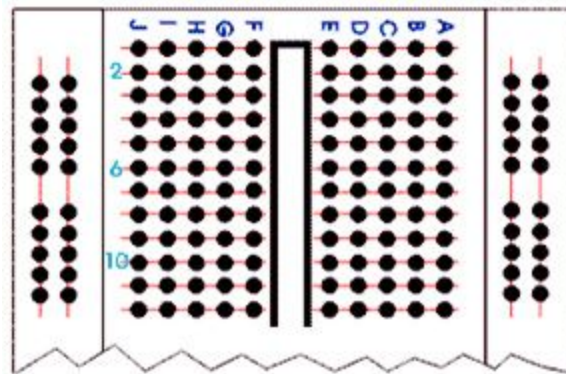

Breadboard Diagram 2

Image Source: TechnologyStudent.com

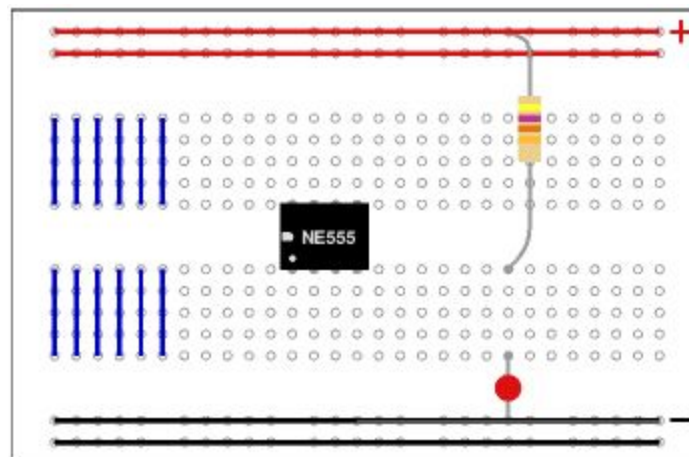

Image Source: Electronicsclub.info



The above diagram shows another example of how the holes of a breadboard are connected. The bottom and the top rows are connected horizontally across the red and black lines, which are the locations of the power supply. The other rows are connected vertically, consisting of five rows and no links across the center. In this way, there are separate blocks of connections to each of the ICs pin. It is always better to link across the wide center gap before you start building circuit to ensure the circuit has power.

How do you code for Arduino?

Arduino uses its own program, called Arduino IDE (Integrated Development Environment), which can be downloaded for free online. The program uses its own coding language, also called Arduino, which is similar to C or C++.

What can you make with Arduino?

Arduino can be used to create a range of different things including robots, traffic lights, light-up clothes and shoes, and small health-based interventions.

Additional Resources

- [Arduino Project Hub](#)¹⁶
- [Programming Electronics Academy](#)¹⁷, including tutorials and project ideas
- Arduino project: [Coffee Cup Spy Camera](#)¹⁸
- [Arduino device to detect lead levels in water](#), developed by an 11-year-old girl, Gitanjali Rao, after the Flint, MI crisis

¹⁶ <https://create.arduino.cc/projecthub>

¹⁷ <https://programmingelectronics.com/arduino-tutorials/>

¹⁸ <https://www.youtube.com/watch?v=bWyFnC-EWnk>



Exercise 1: Basic LED

In this exercise, you'll build a basic LED (light emitting diode) that blinks on and off at a certain frequency. After you build the system using the code provided, try changing the delay parameters to make it blink faster or slower.

Step 1: Assemble the Arduino and breadboard.

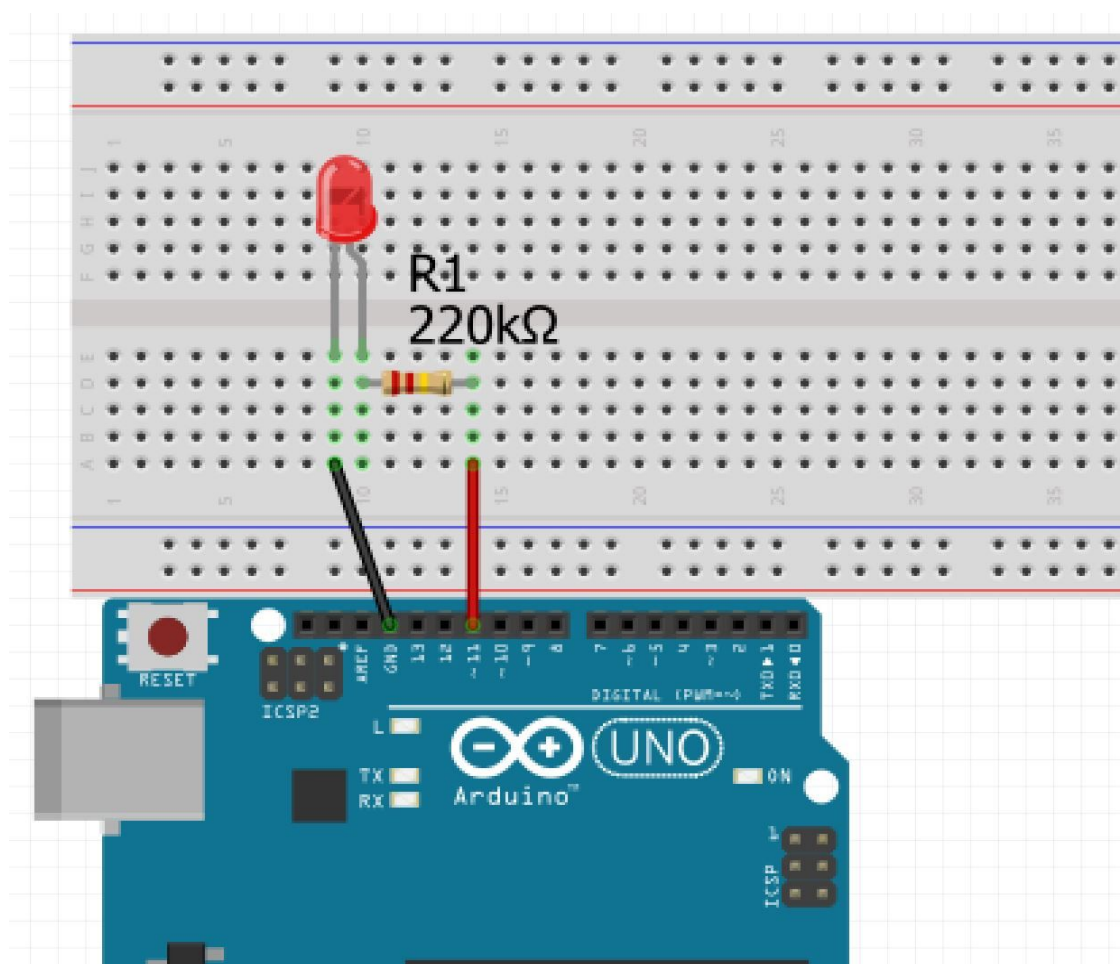

Parts needed:

Arduino board

bread board

1 LED



1 220k Ohm resistor

2 jumper wires



Step 2: Program the Arduino.

sketch_nov27a | Arduino 1.8.8 (Windows Store 1.8.19.0)

File Edit Sketch Tools Help

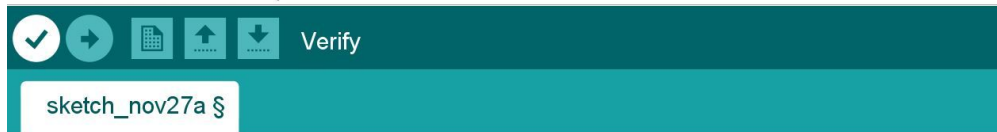

```
int LED1 = 11;           //declares pin 11 to be LED1

void setup() {
  pinMode(LED1, OUTPUT); //declares LED1 to be an output
}

void loop() {
  digitalWrite(LED1, HIGH); // sends signal from pin 11
  delay(3000)                // signal will last 3000 milliseconds(3 seconds)
  digitalWrite(LED1, LOW);  // cuts off signal from pin 11
  delay(4000)                //will delay for 4000 milliseconds(4 seconds)
}

// loop will repeat itself
```



Exercise 2: LED Traffic Light

In this exercise, you'll build an LED traffic light with three lights that cycle through green (go), yellow (slow down), and red (stop). Once you've successfully built the traffic light, try changing the delay parameters and the order of the lights to come up with new patterns.

Step 1: Assemble the Arduino and breadboard.

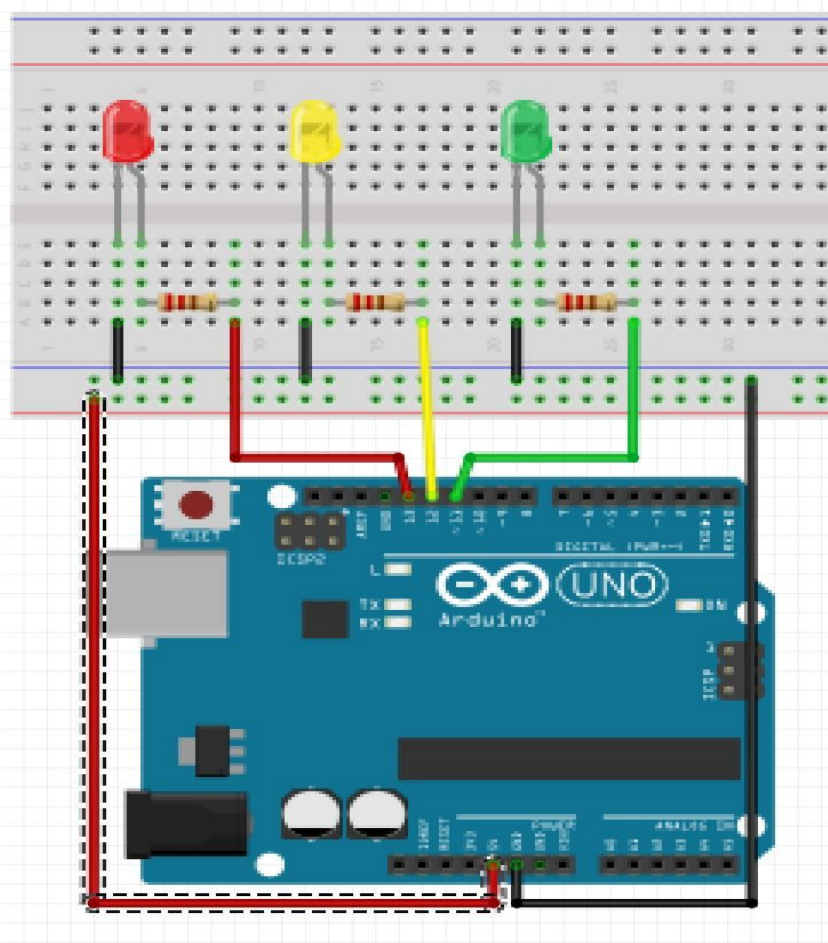

Parts needed:

Arduino board

Bread board



3 LED bulbs

3 220k ohm resistors

8 jumper wires



Step 2: Program the Arduino.

seqlights | Arduino 1.8.8 (Windows Store 1.8.19.0)

File Edit Sketch Tools Help



seqlights \$

```
int LED1 = 13;           // Declares pin 13 to be LED1
int LED2 = 12;           // Declares pin 12 to be LED2
int LED3 = 11;           // Declares pin 11 to be LED3

void setup() {
  pinMode(LED1, OUTPUT); // sets LED1 as an output
  pinMode(LED2, OUTPUT); // sets LED2 as an output
  pinMode(LED3, OUTPUT); // sets LED3 as an output
}

void loop() {
  digitalWrite(LED1, HIGH); //sends signal to LED1
  delay(10000);              // delay of 10,000 milliseconds(10 seconds)
  digitalWrite(LED2, HIGH); //sends signal to LED2
  delay(10000);              // delay of 10,000 milliseconds(10 second)
  digitalWrite(LED3, HIGH); //sends signal to LED3
  delay(10000);              // delay of 10,000 milliseconds(10 seconds)
  digitalWrite(LED1, LOW);  //cuts signal to LED1
  delay(10000);              // delay of 10,000 milliseconds(10 seconds)
  digitalWrite(LED2, LOW);  //cuts signal to LED2
  delay(10000);              // delay of 10,000 milliseconds(10 seconds)
  digitalWrite(LED3, LOW);  //cuts signal to LED3
  delay(10000);              // delay of 10,000 milliseconds(10 seconds)
}
```



Exercise 3: Photosensitive LED

In this exercise, you will create an LED light that responds to environmental conditions—specifically, low lighting. A photo sensor detects light levels and, based on the program you will write, turns on the LED light when light levels fall below a certain threshold and off once light levels rise above. Check your LED light by turning on and off the lights or holding your hands around the photo sensor to block light. This is the same technology that turns street lamps in your neighborhood on and off.

Step 1: Assemble the Arduino and breadboard.

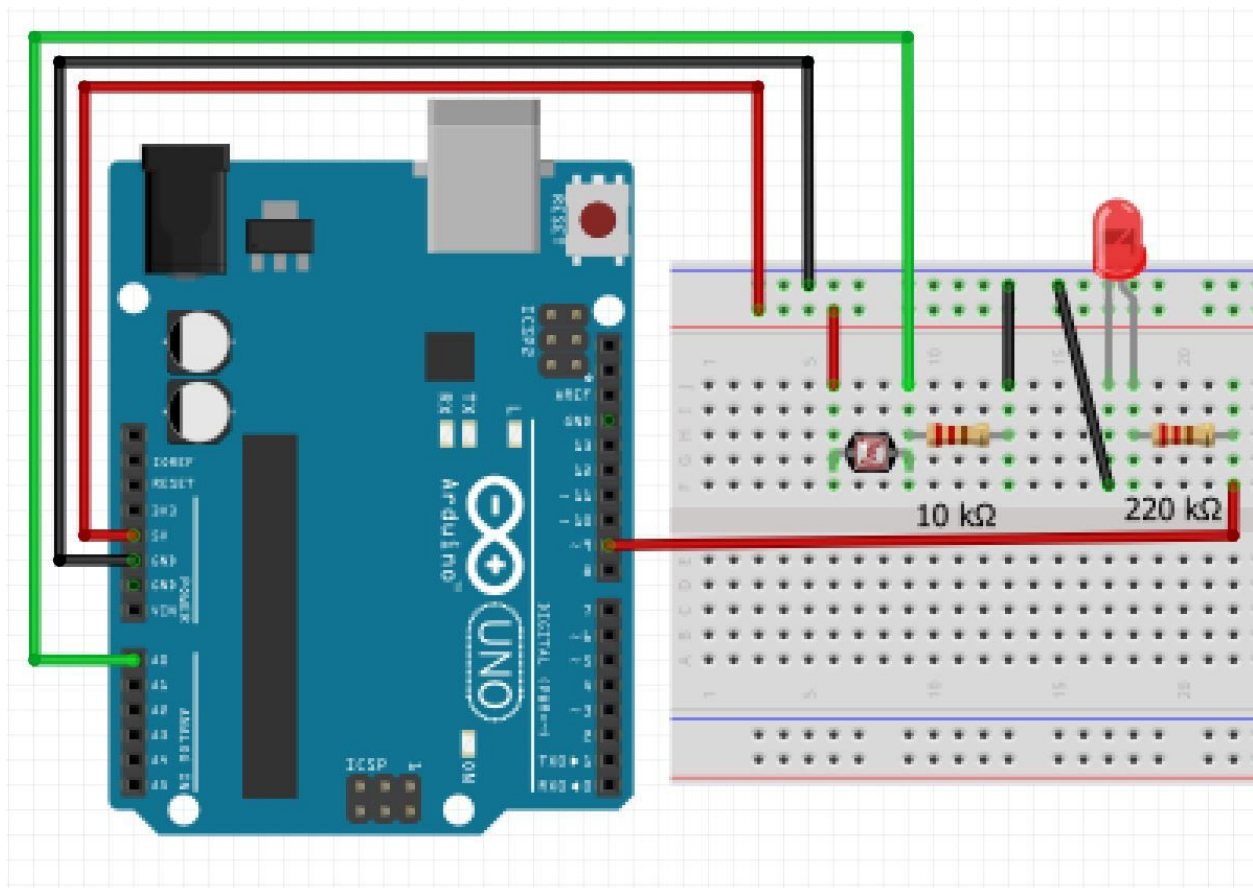

Parts needed:

Arduino board

Bread board



- 1 photo sensor
- 1 LED bulb
- 1 220k ohm resistor
- 1 10k ohm resistor
- 6 jumper wires



Step 2: Program the Arduino.

∞ DIMMYES | Arduino 1.8.8 (Windows Store 1.8.19.0)

File Edit Sketch Tools Help



DIMMYES §

```
/* Use a photoresistor (or photocell) to turn on an LED in the dark
   More info and circuit schematic: http://www.ardumotive.com/how-to-use-a-photoresistor-en.html
   Dev: Michalis Vasilakis // Date: 8/6/2015 // www.ardumotive.com */

//Constants
const int pResistor = A0;           // Photoresistor at Arduino analog pin A0
const int ledPin=9;                 // Led pin at Arduino pin 9

//Variables
int value;                           // Store value from photoresistor (0-1023)

void setup(){
  pinMode(ledPin, OUTPUT);           // Set ledPin - 9 pin as an output
  pinMode(pResistor, INPUT);         // Set pResistor - A0 pin as an input (optional)
}

void loop(){
  value = analogRead(pResistor);

  //You can change value "25"
  if (value < 400){
    digitalWrite(ledPin, HIGH);      //Turn led off
  }
  else{
    digitalWrite(ledPin, LOW);        //Turn led on
  }

  delay(500);                         //Small delay
}
```



Exercise 4: Remote control LED

In this exercise, you'll program two LED lights to be controlled via a bluetooth remote control. When you press a button, the remote control will send a signal to a bluetooth receiver. This information then triggers the lights to go on or off.

Step 1: Assemble the Arduino and breadboard.

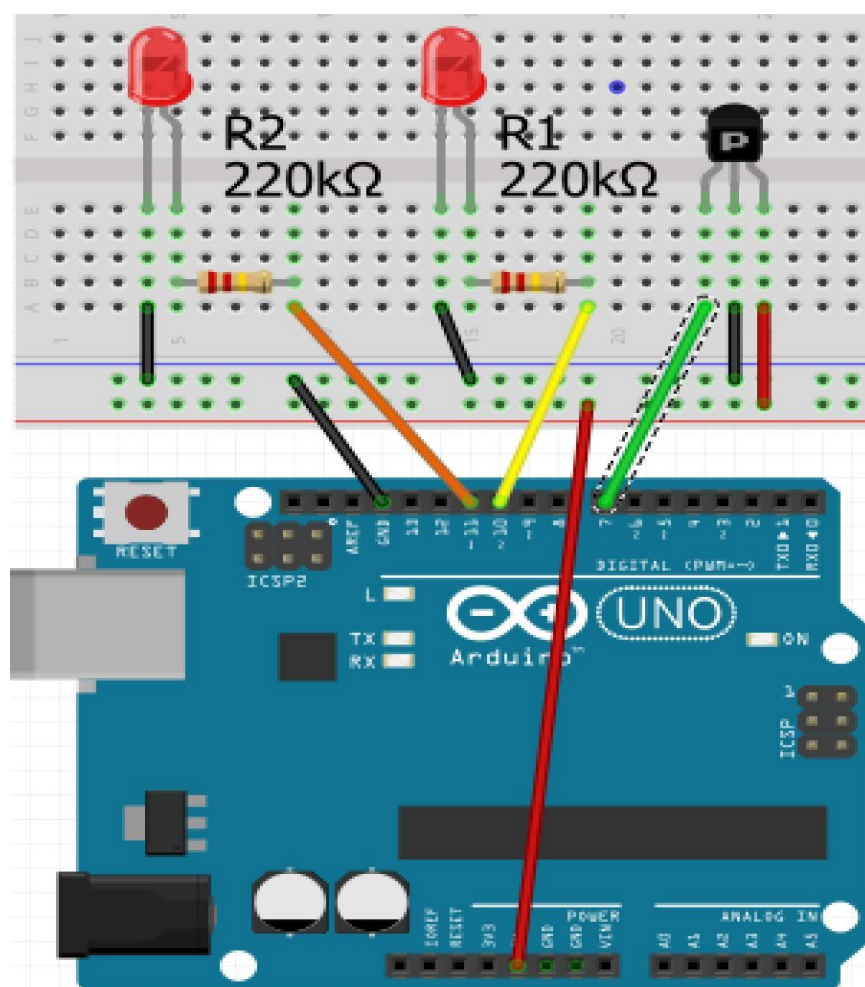

Parts needed:

Arduino board

Bread board



- 1 IR receiver
- 2 LED bulbs
- 2 220k ohm resistors
- 9 jumper wires

Step 2: Program the Arduino.

2LEDREMOTE | Arduino 1.8.8 (Windows Store 1.8.19.0)

File Edit Sketch Tools Help

```
2LEDREMOTE §
#include <IRremote.h>           // include remote library
const int RECV_PIN = 7;        // set pin 7 as receiver
IRrecv irrecv(RECV_PIN);
decode_results results;
const int redPin = 10;         //set led1 to pin 10
const int greenPin = 11;      //set led2 to pin 11
void setup() {
  irrecv.enableIRIn();
  irrecv.blink13(true);
  pinMode(redPin, OUTPUT);     //set pin 10 to output
  pinMode(greenPin, OUTPUT);   //set pin 11 to output
}
void loop() {
  if (irrecv.decode(&results)) {
    switch(results.value) {
      case 0x3D9AE3F7: //Keypad button "2"
        digitalWrite(redPin, HIGH); //turns pin 10 on when button 2 is presed
        delay(2000);
      }
    switch(results.value) {
      case 0xC101E57B: //Keypad button "0"
        digitalWrite(redPin, LOW); //turns pin 10 off when button 0 is presed
        delay(2000);
      }
    switch(results.value) {
      case 0x6182021B: //Keypad button "3"
        digitalWrite(greenPin, HIGH); //turns pin 11 on when button 3 is presed
        delay(2000);
      }
    switch(results.value) {
      case 0x9716BE3F: //Keypad button "1"
        digitalWrite(greenPin, LOW); //turns pin 11 off when button 1 is presed
        delay(2000);
      }
    irrecv.resume();
  }
}
```



Exercise 5: Control servomotor with potentiometer

A *servomotor* is an actuator that rotates according to the position, velocity, and acceleration rate that you set. A *potentiometer* is a sensor that looks like a little metal knob. In this exercise, you'll program a servomotor to turn while you turn the knob of the potentiometer. This is the same as a volume knob from a powers amplifier. This technology powers functions as large as automatic gates and as small as remote-operated toys.

Step 1: Assemble the Arduino and breadboard.

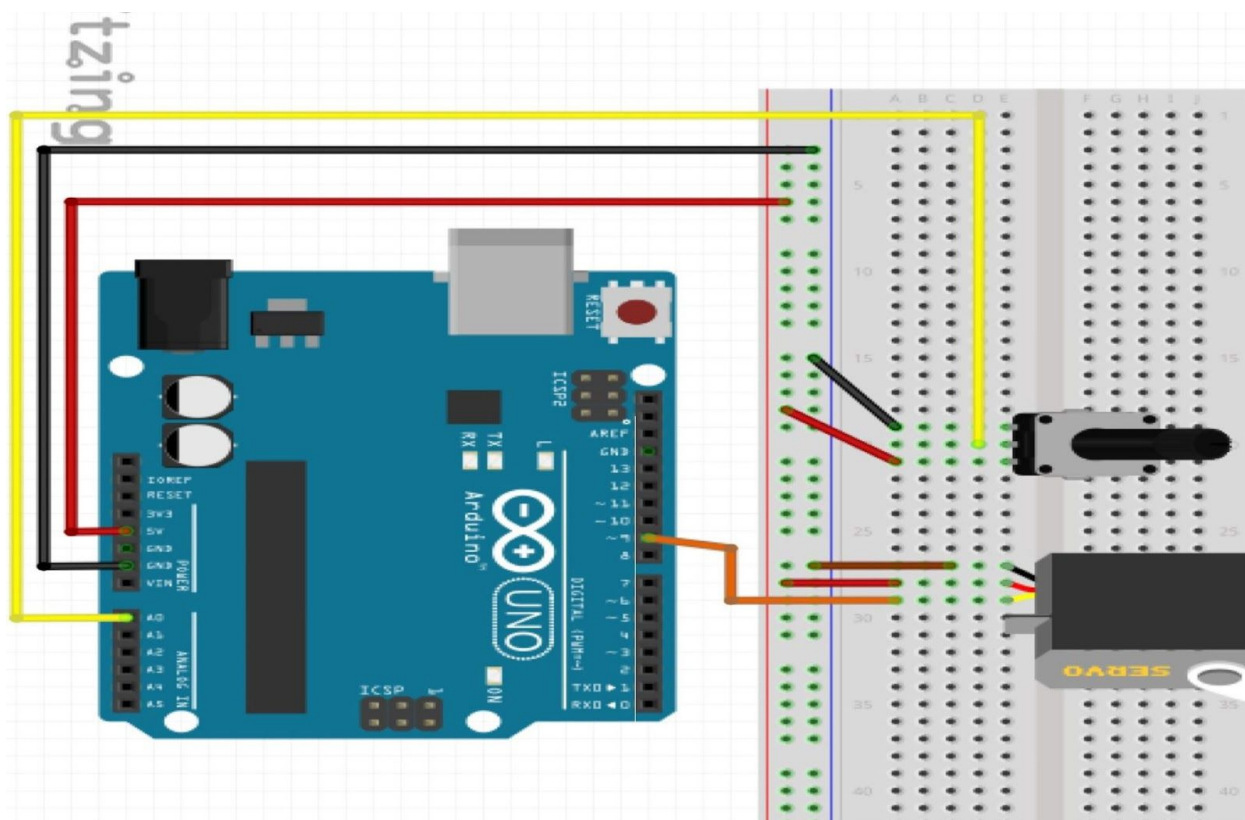



Parts needed:

Arduino board

Bread board

1 potentiometer

1 servo motor

8 jumper wires



Step 2: Program the Arduino.

sketch_oct19a | Arduino 1.8.8 (Windows Store 1.8.19.0)

File Edit Sketch Tools Help

```
sketch_oct19a $
#include <Servo.h> //include servo library

Servo myservo;

int potpin = A0; //potentiometer to pin A0
int val;

void setup() {
  myservo.attach(9); //servo to pin 9
}

void loop() {
  val = analogRead(potpin);
  val = map(val, 0, 1023, 180, 0); // cw or ccw now
  myservo.write(val); //with nob invert 0-1023 or 180-0
  delay(15);
}
```



Exercise 6: Step motor with remote control

A *step motor* (or *stepper motor*) is an electric motor that divides a full circular rotation into a number of equal parts, or *steps*, and rotates according to the number of steps you program. In this exercise, you'll program a step motor to respond to inputs from a bluetooth remote control. This is the same technology that powers garage-door openers, camera lenses, and automated curtains.

Step 1: Assemble the Arduino and breadboard.

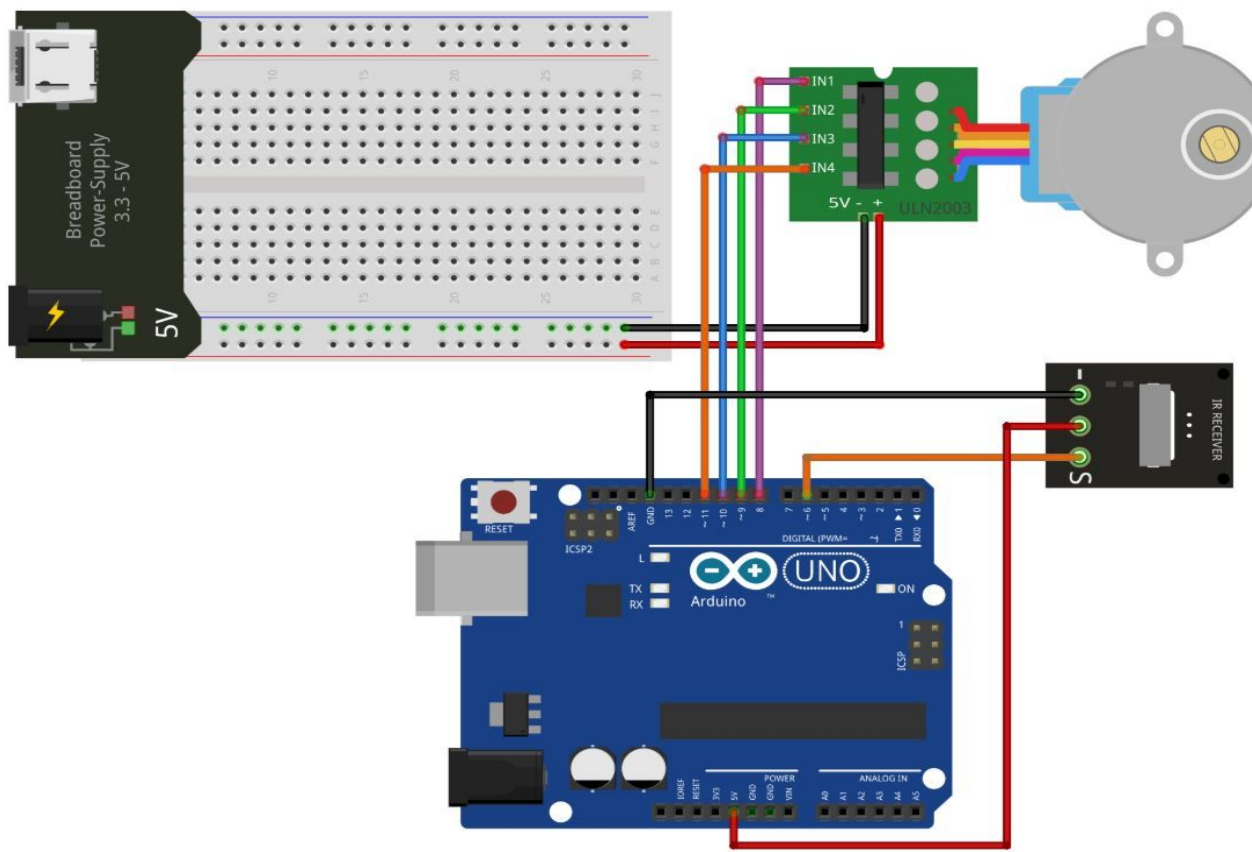

Parts needed:

Arduino board

Bread board

1 IR receiver



1 step motor
1 motor driver
9 jumper wires



Step 2: Program the Arduino.

REMOTE_STEP | Arduino 1.8.8 (Windows Store 1.8.19.0)

File Edit Sketch Tools Help

```
REMOTE_STEP $
#include "Stepper.h"
#include "IRremote.h"

#define STEPS 32
int Steps2Take;
int receiver = 6;

Stepper small_stepper(STEPS, 8, 10, 9, 11);
IRrecv irrecv(receiver);
decode_results results;
void setup()
{
  irrecv.enableIRIn();
}
void loop()
{
  if (irrecv.decode(&results))
  {
    switch(results.value)
    {
      case 0x3D9AE3F7: // 2 button pressed
        small_stepper.setSpeed(500);
        Steps2Take = 2048;
        small_stepper.step(Steps2Take);
        delay(2000);
        break;

      case 0x6182021B:
        small_stepper.setSpeed(500);
        Steps2Take = -2048;
        small_stepper.step(Steps2Take);
        delay(2000);
        break;
    }
    irrecv.resume();
  }
}
```

```
/*----- Variables, Pins -----*/
// Number of steps per revolution of Internal shaft
// 2048 = 1 Revolution
// Signal Pin of IR receiver to Arduino Digital Pin 6

/*-----( Declare objects )-----*/
// Setup of proper sequencing for Motor Driver Pins
// In1, In2, In3, In4 in the sequence 1-3-2-4

// create instance of 'irrecv'
// create instance of 'decode_results'

// Start the receiver

// have we received an IR signal?

//Max seems to be 700
// Rotate CW

// 3 button pressed
// Rotate CCW

// receive the next value
/* --end main loop -- */
```



Exercise 7: Motion trigger alarm

In this exercise, you'll build an alarm that goes off when it detects an object nearby. Once you've built the system, try changing the distance and alarm parameters to see what changes. You can also open a *Serial Monitor* (the magnifying glass icon in the upper right of the Arduino IDE) to view the exact distance the sensor is detecting and feeding as inputs into the Arduino. Move your hand closer and further away to see how the number changes. This is the same technology that powers alarm systems for homes and businesses.

Step 1: Assemble the Arduino and breadboard.

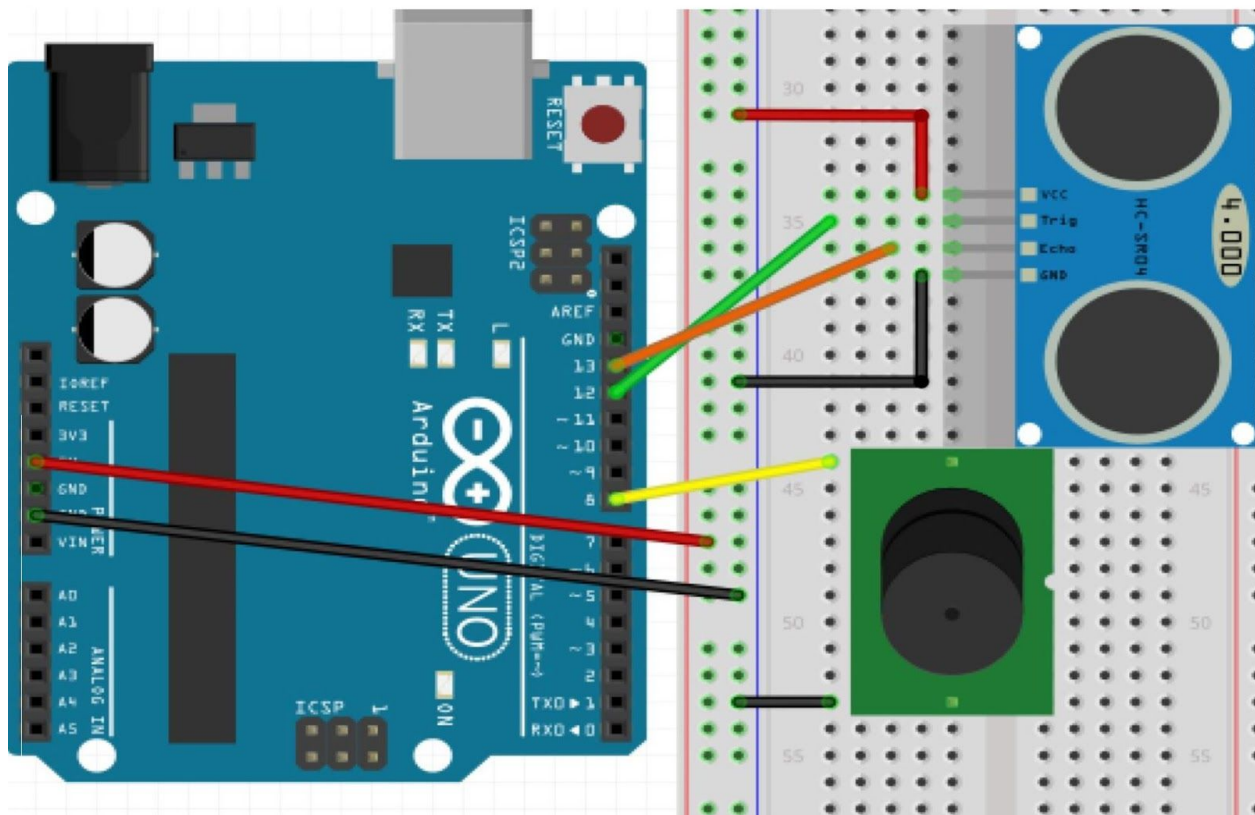

Parts needed:

Arduino board



Bread board

1 HC-SR04 sonar sensor

1 active buzzer

8 jumper wires



Step 2: Program the Arduino.

motion_alarm1 | Arduino 1.8.8 (Windows Store 1.8.19.0)

File Edit Sketch Tools Help



motion_alarm1 §

```
#define trigPin 12
#define echoPin 13
int Buzzer = 8; // Connect buzzer pin to 8
int duration, distance; //to measure the distance and time taken

void setup() {
  Serial.begin (9600);
  //Define the output and input objects(devices)
  pinMode(trigPin, OUTPUT);
  pinMode(echoPin, INPUT);
  pinMode(Buzzer, OUTPUT);
}

void loop() {

  digitalWrite(trigPin, HIGH);
  delayMicroseconds(10);
  digitalWrite(trigPin, LOW);
  duration = pulseIn(echoPin, HIGH);
  distance = (duration/2) / 29.1;
  //when distance is greater than or equal to 200 OR less than or equal to 0,the buzzer and LED are off
  if (distance >= 200 || distance <= 0)
  {
    Serial.println("no object detected");
    digitalWrite(Buzzer,LOW);
  }
  else {
    Serial.println("object detected \n");
    Serial.print("distance= ");
    Serial.print(distance); //prints the distance if it is between the range 0 to 200
    tone(Buzzer,400); // play tone of 400Hz for 500 ms
  }
}
```



Soldering & Electricity

Goals:

- Understand how electricity works
- Understand when, why, and how to solder and desolder components

Key Terms

Soldering station: soldering device composed of three parts: iron stand, power unit and the hand piece.

Iron stand: Piece used to hold the hot iron. This is made up of a heavy-duty metal base and a reinforced spring iron holder.

Power Unit: Component that provides power to the iron via an outside power source.

Hand piece/iron: tool that has a heated metal tip and an insulated hand grip. The iron transmits heat between two pieces for the purpose of transmitting heat and soldering.

Soldering helping hands: A stand with two flexible clips ("hands") to assist in holding pieces in place.

Soldering wire: Material commonly used to solder in electronics. The wire must have a core with flux, a chemical agent that improves contact and strength.

Soldering paste: Material used to connect component and board surfaces during the soldering process.

Desoldering pump or solder sucker: Device that removes solder from a printed circuit board.

Desoldering wick, braid or wire: Finely braided, copper wire used to remove solder. The braid is pressed against the connection, and when heated, removes the solder.



Key Questions:

What is electricity?

Electricity is a flow of electrons from one atom to another.

- Electrons move across atoms based on **electric charge**, or the positive or negative properties that cause either attraction or repulsion.
- The difference in the electric charge between two materials is known as the **voltage**, which is what causes electric charges to move.
- The flow of the electric charge is known as a **current**. These currents flow from one material to another, with some materials being easier to pass through.
- A **conductor** is any material that allows the current to flow to another material.

How do electrical circuits work?

An electric circuit can be thought of as the highway of conductive materials that an electric current flows through in order to power an object. Important elements and functions of an electrical circuit include:

- **Grounding** is a process that allows electric current to return to the earth/ground if something goes wrong with a circuit. For example, if an object's insulation fails, the electrons can be transferred to the ground safely rather than risk electrocution.
- **Capacitors** store energy as an electrostatic field. They are commonly used in electric circuits to block direct currents and allow alternate currents to pass.
- An **amplifier** is a device that increases the power of a signal. Different types of these devices amplify voltage, current, or power.
- A **resistor** is anything that electricity cannot travel through easily. When energy does pass through a resistor, it is often released through another form (for example, changing from electricity to light or heat).

What is soldering?

Under the soldering process, items are joined by heating, melting, and adding a filler material in the joint. In soldering, the work pieces being connected are not melted to connect. Instead, the solder is the metal alloy and connection that creates a strong electrical bond.



Why do we need to solder?

Soldering allows us to connect different pieces in order to create an electrical bond. Soldering creates a permanent connection, but it can be undone through the desoldering process. You would want to desolder when correcting an electrical circuit or removing a component.

Additional Resources:

- [Introduction to Electricity](#)¹⁹ video
- [Electric current](#)²⁰ video
- [What Is Electricity](#)²¹ video
- [Circuit Playground](#)²² interactive definitions
- [Learn to Solder](#)²³ video

Exercise: Soldering a resistor to a circuit board

Goal: In this exercise we'll learn how to solder to make a permanent connection. Even though we'll be working on resistors and a circuit board, soldering skills can be transferred across many different components, including capacitors, LEDs, head pins, etc. Here, we'll be using a resistor as our example since virtually any circuit has a resistor.

To successfully solder, we're going to divide the process into several phases:

- **Phase 1:** Learn how to place the soldering board or wires in a firm state.
- **Phase 2:** Learn how to connect the soldering iron with the soldering wire to place a soldering point to the component we want to solder.
- **Phase 3:** Practice how to feed the soldering wire to create stable and neat solder points.

¹⁹ <https://www.youtube.com/watch?v=EJeAuQ7pkpc>

²⁰ <https://www.youtube.com/watch?v=HXOok3mfMLM>

²¹ <https://www.youtube.com/watch?v=ru032Mfsfig>

²² <https://learn.adafruit.com/series/circuit-playground>

²³ https://www.youtube.com/watch?v=v4D_Rdp1uh8



- **Phase 4:** Learn how to desolder components using desoldering pump and soldering iron.



Foundations of Community Innovation

One of the major disruptions of digital fabrication is that it can democratize innovation, allowing people who have traditionally not been able to design and make their own products to do so. This opens the door to new ideas and forms of expertise and can ultimately lead to more community-based solutions. Community innovation in the Bronx means that Bronx residents, in particular youth, women, and people of color, lead the design and fabrication processes for solutions to challenges they see in our community. Leading this process requires us to build on the everyday expertise of Bronx residents and channel that knowledge into innovations that no one else is talking about.

At the Bronx Innovation Factory, the goal is to connect the lived experience and community expertise that Bronx residents have with digital fabrication skills in order to drive innovation. We believe that the digital fabrication skills learned here can support community innovation and solve some of our community's most persistent hurdles. With these workshops as the starting point, we hope to scale this mindset and connect Bronxites to solutions designed and made by them. Ultimately, the community innovation skills learned here are meant to fuel self-determination, build community ownership, and redefine who is an *innovator*.



Economic Democracy

Goals

- Understand what the economy is and how it works
- Understand how the economy systematically excludes communities like the Bronx
- Understand ways to make the economy more equitable

Key Terms

Economy: How people manage resources to provide for themselves and others.

Economic Democracy: A system where people share ownership over the resources in their communities and participate equally in deciding how they are used. Under economic democracy, the people most affected by a decision get to make the decisions.

Community wealth building: This strategy aims to improve the ability of communities and individuals to increase asset ownership, anchor jobs locally, expand the provision of public services, and ensure local economic stability.

Worker-owned cooperatives: Companies where those who work for the company also own the company and participate in the company's decision-making processes.

Key Questions

How does the economy function?

The mainstream view is that a capitalist economy is the most efficient and progressive. In a capitalist economy, production facilities are privately owned; individual wage workers are employed by business owners; goods and services are produced for market exchange; and consumers purchase the goods and services they need to sustain themselves with money.



Most economic theory that seeks to explain how economies work focuses on enterprise ownership, investment in business, commodity prices, wage levels, consumption patterns, and market fluctuations. In this light, economies are guided by rational laws of supply and demand, as well as growth and competition – and these need to be strictly adhered to if we hope to survive.

Those who take into account the environmental and social costs of privately owned economic growth are currently challenging mainstream views of the economy. Many now see the current mainstream model of the economy as unsustainable.

Looking at the diagram of the iceberg below, economic activities are divided by the water line.

- Above the line are the visible activities that we all see as the real economy—paid work, market exchange, capitalist enterprises.
- Below the water line are all the other activities that also keep us alive, fed, sheltered, cared for and connected to each other. The contribution of these activities is often hidden and unrecognized. Many of these practices deliver well-being directly and need to be safe-guarded. Some of these activities are illegal; they undermine community well-being and need to be controlled.

Our economy is what we make it. We have the right to build a local economy that is just, cares for all, and protects our environmental and social commons.



Image Source: BCDI Economic Development Curriculum

What are some ways that the economy can become more equitable?

There are many changes we could make to create a more equitable economy. One particular strategy is supporting worker-owned cooperatives to build economic democracy. A worker-owned cooperative, or a worker-coop, is a workplace that is democratically owned and run by its workers. But what does that really mean?

- In a traditional firm or company there is an owner, maybe a couple of partners, or perhaps a board of directors. These are the folks who own the company, who are legally responsible for the company, who must make decisions about the company, and who get the profits from the company.
- In a worker-cooperative, the **workers themselves are the owners**. The workers get to **make the decisions** (each coop member gets one vote) and the workers get to **reap the profits** as well.



- Unlike a traditional business, capital is subservient to labor. Workers control what is produced, how to produce it, and who gets what is produced. **The company still has to make a profit**: it must still have a product or service that is in demand in the marketplace, and it must have a good business plan and process for execution. However, **profits are not the only motive**—the drive for meaningful work, for contributing to the community, and other motives are incorporated into the business model.
- One of the most successful examples of a worker-coop is **Mondragon** in the Basque region in Spain. The US also has a long history of successful worker coops, many of which began in the 1960s and 1970s.
- In order to overcome risks around business failure, worker cooperatives cannot exist alone; they must be part of **dense networks of cooperatives** that work with each other to build and grow their individual businesses.

Exercise: What do you know about the Bronx?

Goal: In this exercise, we are going to apply the economic democracy concepts to our community. Reflect on the following questions, and then we'll discuss together as a group.

Reflection Questions

How do people describe the Bronx?

What do you notice about these perceptions?

Why do people think these things?

Do these perceptions differ from the way you think about the Bronx?

Exercise: Build your ideal community

Goal: Design your ideal community using the legos in your bag. Each team should have four people separated into four roles:

- **Banker:** controls access to the legos



- **Designer:** designs the community
- **Builder:** places the blocks
- **Consumer:** can comment on the design and placement, but can't touch the legos

After you've finished building your community, reflect on the following questions:

- Who gets to make decisions about what is built?
- What external factors affect the building process?
- Who should get to make decisions in the economy?
- Thinking about the community you just built, what connections do you see with the Bronx?

Assignment: Your Role in the Economy

Spend the next week identifying the ways that you interact with other people as part of the economy. While buying stuff is one obvious economic interaction that most of us have every day, challenge yourself to identify other economic interactions you might have (particularly ones that might be further down on the iceberg diagram).

Additional Resources

- Read more at [BCDI's website](#)²⁴
- [Fixing the Future, PBS Documentary](#)²⁵ that travels across the US to capture the Solidarity Economy
- Video of [The Mondragon Experiment](#)²⁶

²⁴ bcdi.nyc/economic-democracy

²⁵ <http://fixingthefuture.org>

²⁶ <http://youtu.be/-obHJfTaQvw>



Technology and Society

Goals

- Understand technology as a tool that humans use to accomplish goals
- Understand how technology reflects and can exacerbate existing biases and inequalities
- Understand how women, people of color, and other marginalized groups can use technology in new and different ways

Key Terms

Technology: “The collection of techniques, skills, methods, and processes used in the production of goods or services or in the accomplishment of objectives”

Algorithmic bias: The bias of computers or technologies that reflects the human biases of the original creators, programmers, or coders.

Internet of things (IoT): The network of devices and objects that are connected by way of the internet. More specifically, not only are these objects connected, but they’re able to communicate with one another.

Cloud computing: The use of a network of remote servers to store, manage, and process data. Cloud computing offers fast, flexible, and more widely scaled data services.

Key Questions

How has the evolution of technology affected society?

The history of technology can be split into four industrial revolutions. Looking at the diagram below, the first revolution was based on harnessing water and steam power. This revolution produced textile machinery such as the cotton gin and the power loom, as well as public objects such as gas lamps for the streets. The second revolution was characterized by the use of electricity and resulted in inventions such as the refrigerator, telephone, and elevator. The third



revolution utilized information technology (IT) systems and gave us now common items such as the personal computer and the internet.

The current and fourth industrial revolution is characterized by automation that's made possible by the internet of things (IoT) and cloud technology. By having everyday objects and manufacturing devices connected, sensing, and communicating with one another via the internet, the IoT increases efficiency of certain tasks. Similarly, cloud technology also relies on the interconnected nature of devices and promises efficiency and scale.

Across each of these revolutions, the transformative inventions required people to make tradeoffs that weren't always positive. For example, as the number of factories increased in urban areas during the second industrial revolution, so did the rate of air and water pollution. Today, a significant tradeoff we make for efficiency and convenience is our digital security. Because the IoT is still relatively new, we're still managing solutions for security concerns such as hacks into unsecure devices and surveillance of product users.

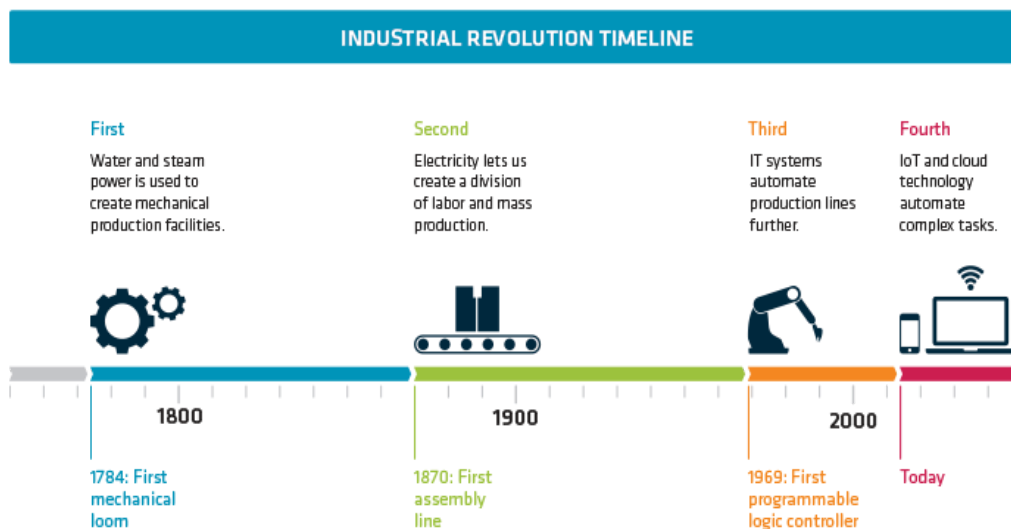

Image Source: <https://mjolner.dk>



Is technology racist?

Technology and, more specifically, artificial intelligence use data trends to find patterns, rules, and associations to predict future behaviors. But, if the data trends that these systems are based on include trends and actions where bias was already present, the artificial intelligence system will reflect those same biases. Humans, who inherently have biases, code these systems and with or without realizing it, translate their own racial, gender, and other biases to the machines they program.

- **Facial recognition software** is an example of where this becomes problematic and dangerous. **Police and law enforcement agencies** are increasingly interested in and adopting this software, but reports have found this technology to be biased.
- **The lack of inclusive coding** is also a problem, as reports continue to find that the tech field predominantly consists of white males. As MIT researcher [Joy Buolamwini](#) [discusses in her TED Talk video](#)²⁷, **who** codes matters, **how** we code matters, and **why** we code matters.
- Not only does the demographic makeup of the tech field affect the products on the market, but it also affects **which products ever come to market**. This is where lived experience is particularly important - those without particular experiences may not see the value, use, or need for a product.
 - For example, one California high school senior created [an app](#)²⁸ to warn and ultimately protect farmworkers from working in extreme heat. This app idea was inspired by her own grandmother's death working in the fields.
- We code not only our biases into technology, but also our ethics. [MIT's Moral Machine website](#)²⁹ gives example scenarios (and allows you to design your own) to show how ethics are built into technology.

²⁷ https://www.ted.com/talks/joy_buolamwini_how_i_m_fighting_bias_in_algorithms?language=en

²⁸ <https://calorapp.org>

²⁹ <http://moralmachine.mit.edu>



Is technology taking our jobs?

The New York Times

BITS

The Week in Tech: Are Robots Coming for Your Job? Eventually, Yes.



Image Source: New York Times

You might have seen newspaper headlines like the one above or heard people share the sentiment that technology is going to eliminate jobs. However, technology is just a tool; people make decisions about which technology to develop and how to use it. Technology can reduce the amount of labor required, but people determine how the benefits of those efficiency gains are distributed.

- In a **traditional business**, business owners often look to reduce the number of employees that have to pay in order to increase their profits. Replacing workers with cheaper technology is just another example of this overarching trend that has been playing out for centuries. For example, the Luddites were English textile workers who protested their employers' use of machines in a deceitful way that didn't follow standard labor practices of the time.
- However, in a **worker-owned company**, the workers decide how to distribute the efficiency. For example, they could get to take

*"If machines produce everything we need, the outcome will depend on how things are distributed. **Everyone can enjoy a life of luxurious leisure if the machine-produced wealth is shared, or most people can end up miserably poor if the machine-owners successfully lobby against wealth redistribution. So far, the trend seems to be toward the second***



more time off while making the same amount of money.

- It matters **who decides** which technologies get developed. Think about the differences between Uber and Mondragón.

How can we use technology to address community challenges?

When tackling long-standing community challenges, technology can both create new solutions and improve upon older ones. In some cases, finding improvements to what's already in place is just as if not more valuable than creating entirely new solutions from scratch. Some local examples of how folks are using technology for real Bronx issues:

- [South Bronx Wireless Mesh Network](#)³⁰
- [Air quality sensors](#)³¹
- Aquaponics and hydroponics ([The Urban Wild](#)³²)
- Urban mouse trap ([Skedaddle Pest Management](#)³³)
- Healthcare tools ([Makernurse](#)³⁴)

Additional Resources

- [Algorithmic Justice League](#)³⁵
- In-depth explanation of the [IoT](#)³⁶
- Data for Black Lives 2018 panel discussion on [Policing and Sentencing in the Age of Algorithms](#)³⁷

³⁰ <https://thepoint.org/digital-stewards/>

³¹

<https://www.citylab.com/environment/2018/07/cheap-sensors-are-democratizing-air-quality-data/563990/>

³² <http://www.theurbanwild.us>

³³ <https://bronxchange.com/users/naceo-giles>

³⁴ <http://makernurse.com>

³⁵ <https://www.ajlunited.org>

³⁶ <https://www.wired.co.uk/article/internet-of-things-what-is-explained-iot>

³⁷ <https://www.youtube.com/watch?v=VjX8qjwxNcw>



- Two articles on the use of Amazon’s facial recognition software, Rekognition, in law enforcement: [Wired](#)³⁸ and [Tech Crunch](#)³⁹
- [AI Cheatsheet](#)⁴⁰ with quick definitions of artificial intelligence-related buzzwords.

Reflection Questions

Have you experienced algorithmic bias in your own life?

How can we counter algorithmic bias?

How can we ensure that technology benefits rather than hurts people?

What are some of the local challenges that technology can address? Think about products and solutions that address the downstream effects of larger, systemic issues.

³⁸ <https://www.wired.com/story/amazon-facial-recognition-congress-bias-law-enforcement/>

³⁹

<https://techcrunch.com/2018/06/25/facial-recognition-software-is-not-ready-for-use-by-law-enforcement/>

⁴⁰ <https://aicheatsheet.comuzi.xyz>



Exercise: Technological Change in Your Lifetime

Goal: Connect some of the technological changes you've seen to life in the Bronx.

Steps:

1. Think about the transformation of technology you've seen in your life. How have these transformations affected the way you spend your time/complete daily tasks/interact with your neighborhood?
2. Draw out a series of pictures that demonstrates this transformation. Include yourself in these images and make sure your series has at least five phases - three that show the transformation in the past, one that shows the present state, and one that shows the next phase as you imagine it.
3. Once everyone finishes, we'll present to each other.
4. Questions to think about after we present: Did this transformation improve your life? Did it go far enough? If this next phase were to happen, how would you want to see it play out?

Assignment: Products that Matter

Goal: Identify a technological product in the world that is marketed as alleviating a systemic challenge and develop a short presentation that supports this product.

Steps:

1. Identify a technological product that's addressing a systemic challenge. This product doesn't need to be addressing the entire challenge (such as generational poverty), but it should address a downstream effect. Once you find this product, spend some time thinking about these questions:
 - Who founded the product?
 - What challenge does this product aim to alleviate? Is it successful? How is success here defined?



- How is the product marketed? Are there changes to the marketing strategy that could make this product reach more audiences?
 - Does the product contribute to building community wealth and ownership?
2. Before the next workshop, develop a 3 minute presentation for this product. The goal of your presentation is to take the position of the inventor and convince the group that this product will make a lasting difference, and ultimately, is worth investing in.
 3. The person with the most compelling presentation will receive a small prize.



The Innovation Process

Goals

- Understand what innovation is and the innovation process
- See yourself as an innovator

Key Terms

Innovation: A new, creative, or imaginative idea, method, or product.

Lived experience: The experience, knowledge, and choices of a person based on their own personal past.

Prototyping: To create a first or preliminary model of a thing that will be used to develop future forms.

Key Questions

What is innovation?

New ideas, devices, or methods applied to the problems people face. At the BXIF we focus on innovations that solve the self-defined challenges of Bronx residents and can build local wealth and ownership.

How is innovation different from an idea or an invention?

An idea is just that an idea. It's the starting point, but it's not actually anything until you build it.

- **Invention** is creating a new product or process.
- **Innovation** is applying something in a new context that solves a challenge that people have. iPod is an example. It wasn't the first device to play music or first way to get it online. But the innovation was making accessible and plugging it into an ecosystem



(iTunes). The “challenge” was people wanting more access to music, and iTunes solved it.

Who is an innovator?

- Anyone! Innovation is not an innate skill. It is a *mindset* that can be taught and practiced by anyone.
- Despite this promise, opportunity and circumstances also matter in determining whose innovations are valued and who gets called “an innovator.”
- Historically, the roles of women and people of color as innovators and collaborators have often been left out of the story. For example, [Einstein’s wife](#)⁴¹ played a huge role in discoveries he has been credited for; however, few know about her important contributions.
- Contemporary examples of [female innovators of color](#)⁴² include women who have designed methods to transform plastic to biofuel, conducting laser-based eye surgery, and invented new methods of cancer treatment.
- People of color, women, low-income people are actually *best* positioned to innovate because they understand exactly how current systems and products are not working. Think about this: People who currently have power and who are well off have no incentive to innovate—the system works for them. People who have little power or material wealth *have* to innovate for their survival.

What is user innovation, and how does it work?

Innovation happens on a regular basis, especially for people who improvise in the face of not having a product that works for them. This *user innovation* is often rooted in daily use or survival, and can spread through user communities experiencing the same challenges. It’s usually not until a significant number of users adopt this product or practice that *producers* even think about producing this product. Only after this innovation appears to be profitable among a wide market will traditional producers and corporations begin to produce.

⁴¹ <https://blogs.scientificamerican.com/guest-blog/the-forgotten-life-of-einsteins-first-wife/>

⁴²

<https://www.bustle.com/articles/87678-8-female-inventors-of-color-whose-innovations-are-shaping-the-future-of-science-and-health>



Some examples of user innovation include:

- [The Sparky Dryer](#)⁴³ - As a solution to solve Uganda's massive food waste problem, 23 year old Lawrence Okettayot created a fruit and vegetable dehydrator that runs on organic waste rather than electricity. The idea was sparked by Okettayot's family's struggles with food waste in farming.
- [Original Creativity Tool Library](#)⁴⁴ - As part of a Detroit-based nonprofit, founder and native Daniel Washington is working to establish a tool library where residents of the NW Goldberg neighborhood can rent out tools. The community has experienced years of disinvestment, but residents worry about future waves of gentrification. The Tool Library is one strategy to equip current residents with the literal tools and knowledge around increasing their property values, and the idea came from conversations with neighborhood residents.
- [The Equitable Internet Initiative](#)⁴⁵ - Based on a partnership with a Detroit-based church, Grace in Action, and internet service provider, Rocket Edge, Grace in Action will serve as a wifi connection spot that provides internet to nearby households. This initiative came out of residents' experiences with failed or no internet access.
- [The AcceleGlove](#)⁴⁶ - An electronic glove that translates American Sign Language to spoken English and Spanish. Developed by Jose Hernandez-Rebollar, the prototypical glove is meant to facilitate communication between deaf and multi-lingual, hearing communities.

What are the steps of the innovation process?

1. **Identify the problem.** As part of identifying the process, one possibly useful exercise can be to map the "[customer job](#)⁴⁷," or all the stages of a problem a person may go through. By mapping out the stages, you might have an easier time identifying where innovation is most useful.
2. **Brainstorm solution ideas.** Conduct your own research of what solutions already exist and what some constraints could be.

⁴³ <https://www.bbc.com/news/business-44579530>

⁴⁴ <http://www.modeldmedia.com/features/daniel-washington-nw-goldbert-12118.aspx>

⁴⁵ <http://www.modeldmedia.com/features/equitable-internet-initiative-073117.aspx>

⁴⁶ <https://www.cbsnews.com/news/talking-glove-speaks-for-the-deaf/>

⁴⁷ <https://hbr.org/2008/05/the-customer-centered-innovation-map>



3. **Design a solution.** Using your various forms of knowledge, create a design for your solution.
4. **Test the idea.** Build a prototype that can be tested in the real world with real people.
5. **Evaluate the solution.** There are a variety of resources out there to help you evaluate your idea. Check out the [“Is it real? Can we win? Is it worth doing?”](#)⁴⁸ and risk matrices to get started thinking about questions you can start asking yourself.
6. **Build the product.** Using your evaluation results, ask yourself: How will I build it? What skills do I need to build it? What materials do I need? Using the answers to these questions, you can start moving towards the building process.

Why do we prototype?

Think about the phrase “Think Big, Build Small.” The goal can be to create something with a big impact, but in order to get there, you need to start small with something called a prototype. The prototype is *not* meant to be the final, best version of your idea – just a quick, rough draft that allows you to **test** your idea and get **feedback**.

The Innovation Mindset

- **Be curious.** Ask how, why, and what if.
- **Collaborate.** You won’t—and can’t—know how to do everything. You need to team up with other people who know how to do things too. Innovators never act alone but build on the findings of those around them. Historically, most innovators have worked as part of teams.
- **Break the rules.** Always ask, “Does it have to be that way?”
- **Embrace risk and learn from failure.**
- **Remix.**
- **Meet true needs.**

Source: [Henry Ford Innovation 101](#)

48

<https://hbr.org/2007/12/is-it-real-can-we-win-is-it-worth-doing-managing-risk-and-reward-in-an-innovation-portfolio>



Additional Resources

- People of Color in Tech [article](#)⁴⁹ that discusses education and entrepreneurship hurdles and opportunities
- [What is the Engineering Design Process](#)⁵⁰ video
- Innovator example: [Sharon De La Cruz TED Talk](#)⁵¹, featuring her idea for a coding language that incorporates the slang and inclusive language that's regularly used
- Innovator example: NYC-based organization, [Movers and Shakers](#)⁵², that's using augmented reality/virtual reality to create monuments representing marginalized voices
- [NASA scientist Ayanna Howard](#)⁵³ describes the advantage of diversity in innovation, as well as the courage it takes to innovate

49

<https://peopleofcolorintech.com/entrepreneurship/how-do-we-empower-black-and-latinx-owned-businesses/>

50

<https://mass.pbslearningmedia.org/resource/phy03.sci.engin.design.desprocess/what-is-the-engineering-design-process/#.WxVtKIOUsUE>

⁵¹ <https://www.youtube.com/watch?v=CFT6w9NKfCs>

⁵² <https://www.moversandshakersnyc.com>

53

<https://www.npr.org/2017/12/19/569474169/being-different-helped-a-nasa-roboticist-achieve-her-dream>



Assignment: Practicing the Innovation Mindset

Goal: Start using the innovation mindset in your daily life to look at common items and situations with a different eye.

Steps:

1. During the course of a day, go about your life and create a photo list of things you think could be improved. Think about things related to your commute to school, your home, your classrooms, the subway – anything that’s a regular part of your day.
2. Have at least one conversation about an item from your photo list with someone who is also affected by this challenge.
3. Write down why you selected the items you did, what you think could be improved, and some of the main ideas from your conversation.
4. Bring your list and written notes back to the next workshop and be prepared to share your observations.



Product Design

Goals

- Learn about the steps associated with design thinking and why they're helpful
- Get started in thinking about your own product design idea
- Understand how teamwork fits into product design

Key Terms

Iteration: The repetition of a process. In product design, iterating means making incremental changes to improve upon a project or idea.

Design thinking: A solutions-based approach to addressing problems that are rooted in human experience.

Key Questions

How can the design process be the same for very different products?

The design process provides the guiding steps to get at an idea. It is not about dictating the only way to design something. There are so many ways to design a product - this process is meant to guide you from start to finish.

What are some of the steps associated with design thinking?

Similar to the innovation process described in the last section, the five phases of the design thinking are:

- **Discovery.** Identify and understand the challenge at hand. A key element in this phase is empathizing and understanding the perspective of those who are most affected.



- **Interpretation.** Based on the conversations and observations you had during the last phase, interpret what you saw and heard to start building ideas for solutions that may be helpful.
- **Ideation.** Using your own observations and discussions with other people, come up with ideas to solve the challenge.
- **Experimentation.** Build a simple prototype of an idea and test its function in the real world.
- **Evolution.** Think about and discuss how your prototype functioned. Did people like or use it? Does your idea work? How can it be improved? From these questions, update your idea and continue building your product.

Can my ideas change as I go through the design process?

Absolutely. The first idea isn't necessarily the best or final one. Your ideas will probably change the more time you spend designing and planning, but this is how you find the right one. Don't spend too much time trying to come up with the perfect product idea before you begin the process - you'll get there. The key part of coming up with the big idea is **doing something** about the problem you see - this is what separates innovators from thinkers.

What's the role of teamwork in product design?

Discussion and working with others is a key part of product design. Even if you're working on a solo project, talking with people about your idea will help you think of new aspects you might not have thought about on your own. We all have blind spots – in the same way that you're an expert on your own lived experiences, someone else's experience and expertise might provide insight on your idea you didn't realize you were missing.

Additional Resources

- [Design Kit Methods](http://www.designkit.org/methods)⁵⁴ from IDEO includes all the different steps of the design process
- [Working in Groups](https://learningcommons.ubc.ca/student-toolkits/working-in-groups/)⁵⁵ Best Practices video

⁵⁴ <http://www.designkit.org/methods>

⁵⁵ <https://learningcommons.ubc.ca/student-toolkits/working-in-groups/>



- [The Engineering Design Process: A Taco Party](#)⁵⁶
- [How to Solve a Problem Like a Designer](#)⁵⁷
- [The World is Poorly Designed, But Copying Nature Helps](#)⁵⁸
- [How to Make a Cardboard Prototype](#)⁵⁹

Exercise: Ideation in Teams

Goal: Using the written/photo list created last week, work together in teams of three to talk about some of the regular challenges you encounter and begin brainstorming products that address this challenge.

Steps:

1. Meet together in pairs and discuss what each of you thinks is your most interesting item from your photo list.
2. Talk about these 3 challenges and brainstorm different ways you'd address them. No ideas are bad at this stage! The goal is to come up with as many ideas as possible.
3. Come to an agreement about which challenge you want to address together for your final project idea. From here, write or draw out the different prototype ideas you might want to pursue.
4. Using available materials, create a quick prototype of your solution. If you need ideas for what type of prototype, check out this poster with [examples of prototypes](#)⁶⁰
5. Present this prototype to the group, explaining how your solution is meant to function, and how you plan to build it.

⁵⁶ https://www.youtube.com/watch?v=MAhpfFt_mWM

⁵⁷ <https://www.youtube.com/watch?v=wOrmr5kT-48>

⁵⁸ <https://www.youtube.com/watch?v=iMtXqTmfta0>

⁵⁹ https://www.youtube.com/watch?v=k_9Q-KDSb9o&feature=youtu.be

⁶⁰ http://provide.smashingmagazine.com/justbuildit_poster.pdf



Assignment: Continue the Design Process

1. Using feedback from the class presentations, work on updates or changes to your solution. Think about the different design and machine considerations to make these updates.
2. Over the next couple of weeks, bring your drawings and prototypes into digital designs that can be produced with the BXIF machines.



Product Lifecycle and Sustainability

Goals

- Understand where our products come from and where they go when we're done with them
- Understand how design and different manufacturing processes can reduce or increase environmental impact

Key Terms

Planned obsolescence: The design and production of items that will break or become unusable to the point of needing replacing. This is done by frequently changing the design (e.g. iPhones), discontinuing parts, or using weak and nondurable materials.

Renewable resources: A resource (usually energy) that can be naturally renewed over a period of time (that is equal to or less than the time it takes to use the resource). For example, solar energy is renewable, whereas oil and gas are not.

Biodegradability: The ability to break down or decompose by natural, living things (such as bacteria).

Greenwashing: Marketing strategy that promotes a product or policy as being more eco-friendly than it really is.

Sustainable design: Design that meets present-day goals and needs without disrupting future generations' abilities to meet their own needs.

Supply chain: The series of processes that include the sourcing of raw materials, production, distribution, and transportation for a commodity.



Key Questions

Where does our stuff come from?

In our daily lives, we consume a lot of stuff. Food products, school supplies, and clothing are just a few examples of daily consumption goods that have environmental impacts and generate waste. Before we buy stuff in the store, that thing likely had an entire global journey:

- First, the location of the original ingredient(s) or material(s),
- Next to the location(s) of the manufacturer(s),
- Next to the location(s) of the distributor(s), and
- Finally to the location(s) of the retailer(s).

Not only are there labor and environmental impacts associated with the activities at each of these locations, but there are also the impacts of transportation between each of these locations. As an example, think about your iPhone. This [slideshow](#)⁶¹ is a few years old, but it highlights the different places, people, and processes that make iPhone production possible.

Where does our stuff go when we're done with it?

Once we throw away our stuff, it likely goes in one of three places:

- **Landfill.** In the US, over half of our waste goes into landfill where it's buried in plastic-lined ditches. The waste is stored in the landfill where some of it (though not all) will eventually breakdown over the course of decades.
- **Recycling or composting centers.** For the recyclable waste that goes to recycling and composting centers, waste is processed and turned into other consumable good (examples: paper, plastics, compost).
- **Trash incinerators.** The waste that goes to trash incinerators is turned to ash after being burned in hot incinerators.

⁶¹ <https://prezi.com/txoe7wpbfne/life-cycle-of-an-iphone/>



While it's preferable to recycle and reuse materials when possible, we should also be striving to reduce the amount of waste produced at all, starting at the manufacturing phase. Here, imagination and ingenuity can help us design processes that aim for zero waste.

Is digital fabrication greener than traditional manufacturing?

When it comes to digital fabrication, *how* the tools are used is the greatest factor in its environmental impact.

- Material and/or product waste is not the only ecological impact generated by manufacturing. Some of the major impacts include energy consumption, material use, and machine emissions.
- At the level of production at the Bronx Innovation Factory, many of the environmental impacts can be controlled or reduced by following printing and cutting best practices around orientation and materials use. For example, when 3D printing, three tips to reduce the environmental impacts include:
 - Print hollow parts (versus solid).
 - Check the product orientation for the fastest printing and least necessary material use.
 - Choosing better, less toxic materials to print with. An example of better printing material is PLA.

How can we design more sustainable products?

Designing more sustainable products requires using sustainable, green materials, minimizing waste, and reducing energy consumption. A few reminders for sustainable design include:

- At the design phase, think beyond the product's use and consider its entire lifecycle from manufacturing, transportation, use, and disposal.
- The biggest areas to consider: energy spent and materials wasted.



Green Design Checklist

- Optimize the product lifecycle.
- Design for disassembly and plan for your product's next life.
- Choose materials that are abundant and sustainable.
- Make recycling part of your design strategy.
- Avoid materials that increase pollution.
- Prioritize energy efficiency with:
 - Efficient design
 - Sustainable power sources
 - Materials with low embodied energy
- Use fewer resources by lightweighting your designs as appropriate.
- Design products to last.

Source: Crowd Spring "Product Design Strategies for a Sustainable Future."

Additional Resources

- [The Story of Stuff](#)⁶²
- Extreme green 3D printing in the desert: [Solar Sinter Project](#)⁶³
- [Natural, fungus-based shipping material](#)⁶⁴ as an alternative to styrofoam, inspired by the inventor's childhood on a farm
- [Adidas Made a 3D Printed Shoe Out of Plastic Waste from the Ocean](#)⁶⁵

Exercise: Mapping the Life of a Product

Goal: This exercise will illustrate how global supply chains work by highlighting the range of locations, processes, and people that make it possible to consume a single product. For this exercise, we'll be looking at a chocolate bar.

⁶² <https://www.youtube.com/watch?v=9GorqroigqM&vl=en>

⁶³ <https://vimeo.com/25401444>

⁶⁴ https://www.youtube.com/watch?v=6X7PwNY8H_4&feature=youtu.be

⁶⁵ <https://www.entrepreneur.com/article/253890>



Steps:

1. Identify all the materials that go into this chocolate bar. Think about each of the different ingredients as well as the wrapper.
2. Match each of the raw materials with their countries of origin:
 - _____ – West Africa, Central and South America, and parts of Asia
 - _____ – worldwide, depending on the type of nut
 - _____ – West Indies, North America, and Australia
 - _____ – Brazil (primarily), India, and China
 - _____ – North America
 - _____ – California, Turkey, Chile
 - _____ – United States
 - _____ – United States, Europe, Brazil, and Mexico
 - _____ – Madagascar, Indonesia, China, and Mexico
3. Map each of these ingredients to each of their different process locations. Don't forget to identify the modes of transportation between locations. Use the Mapping the Supply Chain Worksheet below.

Reflection Questions

Do supply chains change the way you think about these products? If yes or no, why and how?

What kind of positive and negative effects do you think a supply chain has on the people involved? Effects on the environment?

What are some ways that a supply chain could be shortened? Do you think it should be shortened? Why or why not?

Can you think of any products whose supply chain is completely within New York City? What about New York State, or the US?

How easy do you think it is to find information about the corporations making this product and their supply chains? Do you think that it should be easier/more difficult?





Mapping the Supply Chain Worksheet

Countries of Origin



Manufacturer Location

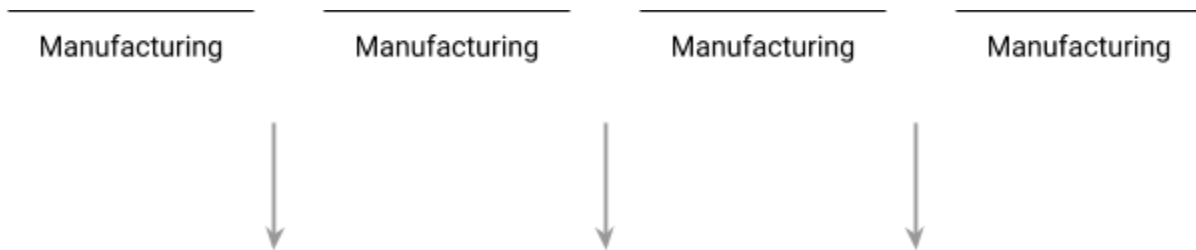

Distributor Location

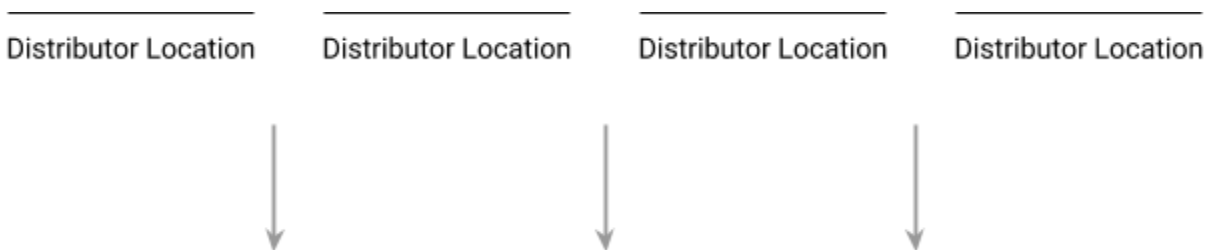

Purchase Location



Purchase Location

Purchase Location

Purchase Location

Final Price: _____



Intellectual Property

Goals

- Understand how innovation relates to intellectual property and wealth creation
- Understand different models of managing, sharing, and protecting intellectual property

Key Terms

Intellectual property (IP): inventions or creative works to which the creator has rights. This protection can come in different forms, including patent, copyright, and trademark.

Patent: A government-authorized license that grants the sole right to an invention. This excludes other individuals from making, using, or selling the patented invention for a set period of time.

Copyright: The legal right that grants the creator of a work to exclusively print, publish, perform, and record artistic material.

Trademark: A legally registered use of a word or symbol as a representation of a company or product.

Key Questions

Where does the concept of “intellectual property” come from?

The concept of intellectual property is tied to private property laws. These laws have been supported by the notion of “[tragedy of the commons](#)”⁶⁶, which starts with the claim that all people act in rational self-interest. As a result, if all people use common resources with no regard for others, all common resources will eventually be depleted. The article uses a metaphor of cattle grazing to demonstrate the point.

⁶⁶ https://www.garretthardinsociety.org/articles/art_tragedy_of_the_commons.html



- Under this metaphor, every herder gains a lot from adding an additional cow to their herd and only suffers a little from the environmental degradation wrought by the addition of that cow.
- As a result, herders are incentivized to add more cows. But if everyone does this, the entire grazing area will be depleted very quickly.
- In order to avoid complete depletion, the only solutions are privatizing or regulating access to common resources.

This argument has been used to support a lot of private property laws, including intellectual property. But there are several problems with it:

- People are not necessarily as selfish as the story states. Lots of people care about the effect of their actions on others, and people have been using cooperative strategies since the dawn of time. Some people argue that the very existence of private property laws is an example of cooperation, so you can't say that people only ever choose their "self-interest."
- The metaphor of cattle grazing doesn't apply to all kinds of goods—including intellectual property. In the digital age, replication and dissemination of intellectual property doesn't necessarily deplete that resource in any way. It can, in fact, grow the value of the resource as it gains wider distribution and notoriety. Moreover, guarding intellectual property too closely prevents us from innovating and building on top of old ideas. This holds economic growth back overall.
- Attempts to guard intellectual property too zealously actually encourage piracy. Research shows that people are generally willing to pay for a work until it becomes too hard to access. Once access is too difficult, people find pirated ways to access. Once pirating starts, it's hard to shift back to purchasing.

What is open source?

Intellectual property made available via a license in which the copyright holder provides the rights to study, change, and distribute the software to anyone and for any purpose. An example of this is Linux.

What is copyleft?



An arrangement whereby software or artistic work may be used, modified, and distributed freely on the condition that any future software or work is also free for use, modification, and distribution. In the software world, this is also known as “free software,” and emphasizes the rights and freedoms of individual users to have access to and tinker with the software going forward.

This is *not* what we’re proposing. We think innovation is best served when people can still derive profit from it, but they can’t prevent other people from doing the same. Once info and IP is freely available, it means that people will invest more in innovation and differentiation versus just trying to defend their intellectual property. This will make all products better and allow us to use technology in ways that people in power are not willing or able to use it now.

What is an IP Free Zone? How can this support innovation?

An IP Free Zone is about sharing IP rapidly to encourage collaboration and innovation. If implemented, this becomes a competitive advantage for the Bronx, as it encourages everyone to continue to be part of the community and contribute to it. This also allows us to adapt rapidly—which is what ensures long-term survival of an economic ecosystem. Without this, there’s the risk of reaching your peak, no longer innovating, and when conditions change, you fade away.

Additional Resources

- [TED Talk](#)⁶⁷ with Arduino creator, Massimo Banzi, on open-sourcing imagination

Exercise: Shenzhen Documentary

Goal: Watch the [Shenzhen Documentary](#)⁶⁸. Think about and discuss the following questions:

⁶⁷

https://www.ted.com/talks/massimo_banzi_how_arduino_is_open_sourcing_imagination?referrer=playlist-open_source_open_world

⁶⁸ <https://www.youtube.com/watch?v=SGJ5cZnoodY>



Reflection Questions

Did Shenzhen's ecosystem make you rethink patents and IP protection? Why or why not?

How does Shenzhen's ecosystem support innovation? Is this what you'd expect?

What connections do you see between the Shenzhen's larger city forces and innovation and the Bronx's larger forces and innovation?

Does the documentary make you rethink the role of innovation?



Developing a Pitch

Goals

- Learn about the components of a strong pitch
- Build confidence in developing your own pitch

Key Questions

Why do I need a pitch?

A pitch is about persuasive speaking. While we usually think of pitches a business opportunity to gain project investors, this is only one form of pitching. In reality, you pitch all the time - when you try to convince your parents, friends, and teachers to do a particular thing.

In this workshop, we're going to develop a pitch for your final project. Think of this as an opportunity to speak to a group persuasively about why they should believe in your product.

What should my pitch include?

There is a lot of material out there that describes the different elements of a pitch. To summarize it, your pitch should address these questions:

- Who are you?
- Why should we care?
- What are you selling?
- Who are you selling to?
- Who are your competitors?
- What is the price?
- What do you need?

How do I develop a pitch?



Developing a strong pitch has several key components that can be broken up into various pieces. These steps can help you think through some of the main considerations for developing convincing content and connecting with your audience.

1. Audience: Know your audience and build empathy.

- *Get to know the audience.* Your audience will be made up of different groups - decide who is the most crucial to focus on based on your idea. From here, think about how to connect and reach this group. The more you know about this group, the more easily you can influence them around your idea.
- *Find common ground.* Related to knowing your audience, identify your shared experiences and common goals.
- *Understand the audience's power.* Your audience came to your pitch to determine what they can do for you. As a result, they are the ones with the power to reject or deny your idea.

2. Message: Develop persuasive content.

- *Define the big idea and provide content that supports that idea.* As you develop your content, identify your point of view and what's at stake. Build clear and organized content around these elements.
- *Develop a clear, concise and strategic presentation.* In developing your presentation, remember to focus on your main point, stay on topic, and set the right expectations. Identify the change you want the audience to come away with, and follow this through the presentation.
- *Speak in clear, regular language.* The pitch should feel conversational rather than lecture-like. Avoid jargon as much as possible.



- *Anticipate resistance.* Your audience may express different forms of resistance (emotional or practical). Knowing these points ahead of time can help you strengthen your pitch and be ready for questions.

3. Story: Use storytelling principles and structure to engage your audience.

- *Craft a beginning, middle, and end to the presentation.* Begin in a place where your audience recognizes the need for a solution. In the middle, let the audience know what could be possible with your solutions. Finally, the end should define the rewards of your solution.
- *Use personal stories to bring in an emotional element.* People connect with people. In your pitch, don't be afraid to communicate why this idea is important to you through your personal experiences.
- *Create memorable elements.* You want your audience to walk away from your presentation with facts or images that will stick with them and, hopefully, propel them to action. Use shocking (true) statistics, dramatic visuals, or an emotional story to create these memorable elements.

4. Media: Identify the best modes for communicating your message.

- *Make the most of your slides.* Whether using PowerPoint, Google Slides, or another medium, visualize your ideas as much as possible. Rather than write out each of your points, only place the most important elements on the slide. When presenting, use your presenter notes to help you through all the content.
- *Check your timing.* Planning the exact amount of time you'll be speaking ahead of time can be difficult. Prepare enough content for 60% of your time to get started,



and acknowledge that this could run the entire time. Add or cut as appropriate after rehearsing.

5. Slides: Conceptualize and simplify the display of information.

- *Produce simple slides with limited text, coordinated visuals, and a single idea per slide.* Give your audience something they can “get” within 3 seconds of looking at your slide. You can do this by limiting your text, including informative visuals, and making sure each slide conveys a single idea.
- *Design for unity.* Design your slides to flow from one to another, both visually and message-wise. Make sure the most important elements are quickly identifiable.
- *Design clear visuals.* Your visuals will be some of the most important elements of your presentation. It’ll be important to turn your words into diagrams, but remember to avoid visual cliches. Further, ensure the data you mean to convey is understandable.

6. Delivery: Deliver your presentation authentically

- *Rehearse!* One of the most important ways to prepare is by practicing your pitch, both on your own and in front of others. Consider recording yourself during rehearsal so you can identify your tone, stance, and any elements you’d like to change.
- *Be familiar with the setting.* Ahead of your presentation, visit the venue if possible and know the schedule. On the day of the presentation, be sure to get there early to avoid wasting too much time on technology glitches.



- *Manage stage fright.* If you're feeling nervous or anxious, it's completely normal - most people feel this way before a pitch! Remember that your audience is also human, and don't forget to breathe before and during the presentation. If you have voices of self-criticism running through your mind, try your best to turn them off.
- *Be yourself.* You are the one people want to connect with. Be available and sincere in your presentation, and show your emotion in your face and voice.
- *Communicate with your body.* Your body language communicates a lot to your audience. During the presentation, have an open stance with your arms uncrossed and straight posture. Remember to look at your audience and use gestures (for example, arm movements) to match the content.
- *Show your enthusiasm!* This is your opportunity to speak about a product that matters to you - don't be afraid to let this show.
- *Get the most out of Q&A.* This is where your prep work around knowing your material and your audience can help you. Anticipate the questions that will be asked, and give yourself time to consider your answers.



Exercise: Rapid Pitching

Goal: Practice persuasive speaking with a randomly assigned object.

Steps:

1. After receiving your object, spend 2 minutes developing a pitch that addresses the essential pitch questions above.
2. Pitch to the group for one minute.

Assignment: Find Examples of Good Pitches

Look for examples of good pitches and bring them to the next workshop. Think about what stood out about the pitches you chose and answer the following questions:

- What speech tactics did the speaker use? What did he/she do right? What could he/she have improved on?
- Did the pitch or speech change your ideas at the end?
- What do you want to use for your own pitch?

Assignment: Develop Your Pitch

Using the steps above, develop a pitch for your final project. Some details to keep in mind as you work on these steps:

- The audience will include the group and BCDI staff, but might also include some outside guests.
- The length of your presentation should be approximately 10 minutes.